

Rapidscreen Assembly Instructions

1: Remove the screen from the carton

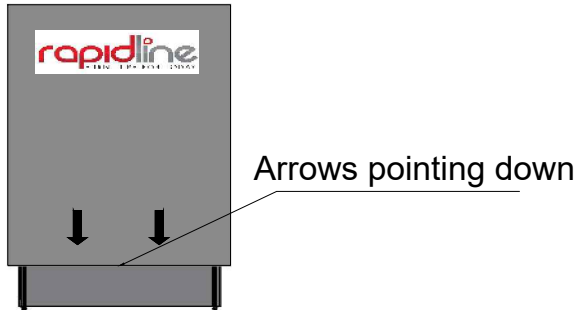

2: Remove the top cap from the side to be joined

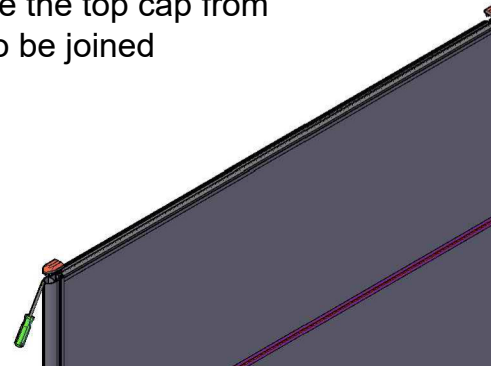

3: Remove the joining pole top cap, and joining strips from pole



4: Align pole and screenjoining grooves and insert aluminium joining strips. Be sure to ensure that both pole and screen are aligned down their entire length to ensure easy entry of the joining strip, it should not need to be forced and should insert easily with a small shake of the screen.

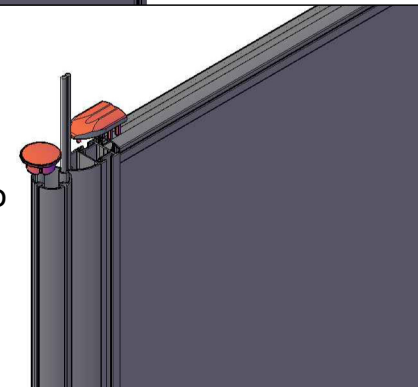

5: Add the required number of screens to the joining pole

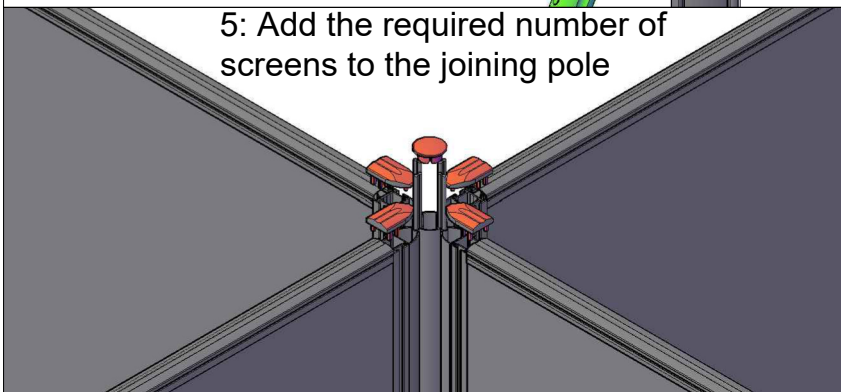

6: Replace the top caps to both the screen and pole, and adjust finished screen height using the supplied foot adjusting spanner.

