

GWA18 ASSEMBLY INSTRUCTIONS

PART LIST

Part No	Component	Quantity
01	RH Back	01
02	LH Back	01
03	RH SIDE	01
04	LH SIDE	01
05	Bottom Channel	01
06	Bottom Front	01
07	Bottom Tray	01
08	Top	01
09	RH DOOR	01
10	LH DOOR	01
11	Top Hinge Pin (Straight)	02
12	Bottom Hinge Pin (with head)	02
13	Top Shelf	01
14	Partition	01
15	Small shelves	02
16	Coat rail (hanger Rod)	01
17	Door Stoppers	04
18	Rivets 4x8	56
19	Rivets 4x8 STEEL	02

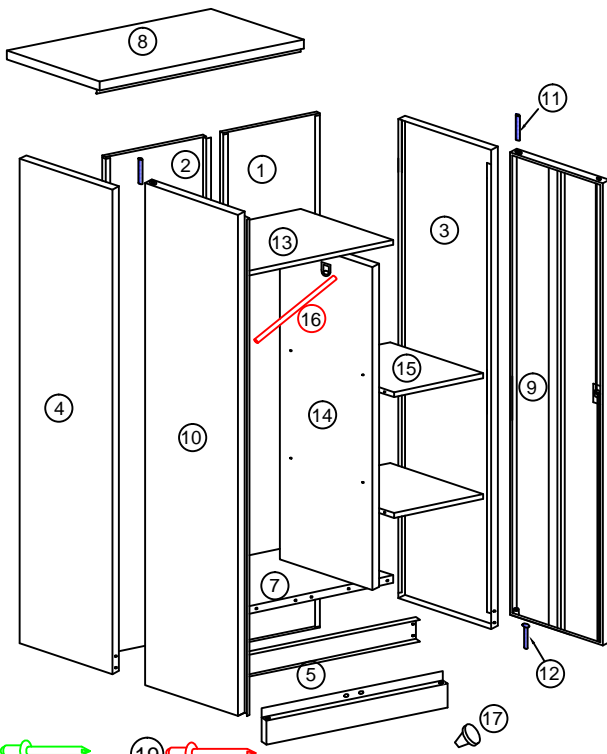

STEP-1

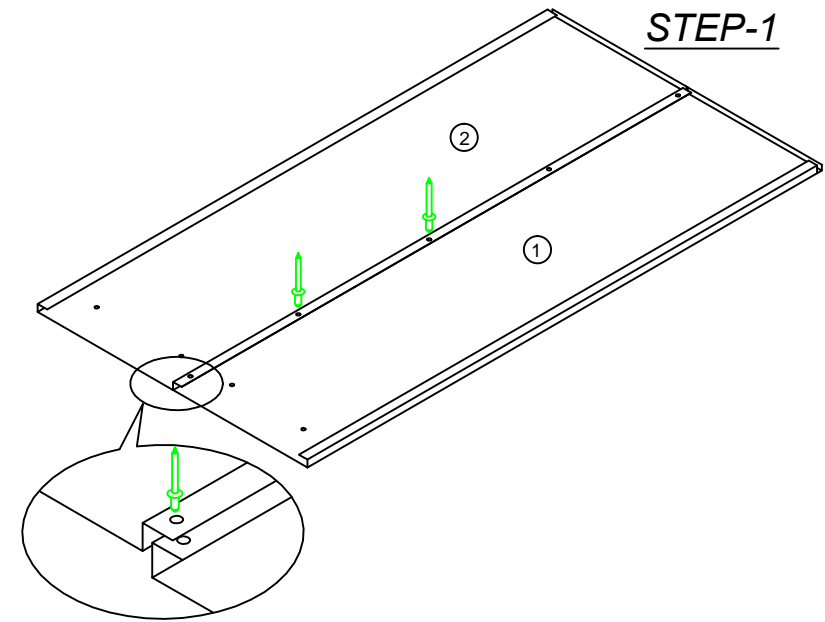

1. Place the RH back on the assembly table.
2. Place the LH back on the Right hand back fold as shown and rivet.

STEP-2

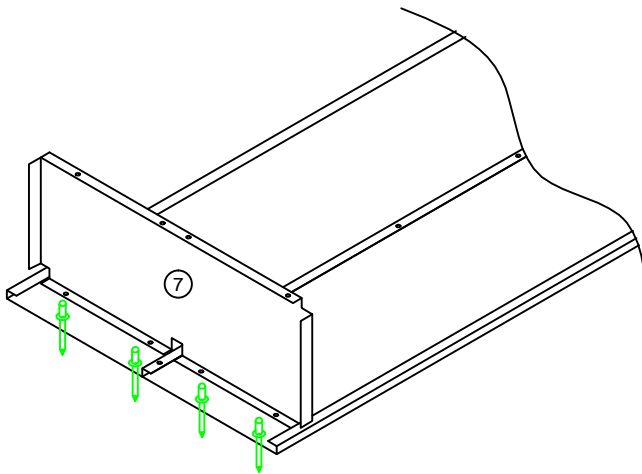

Fix the Bottom tray as shown and Rivet from outside.

STEP-3

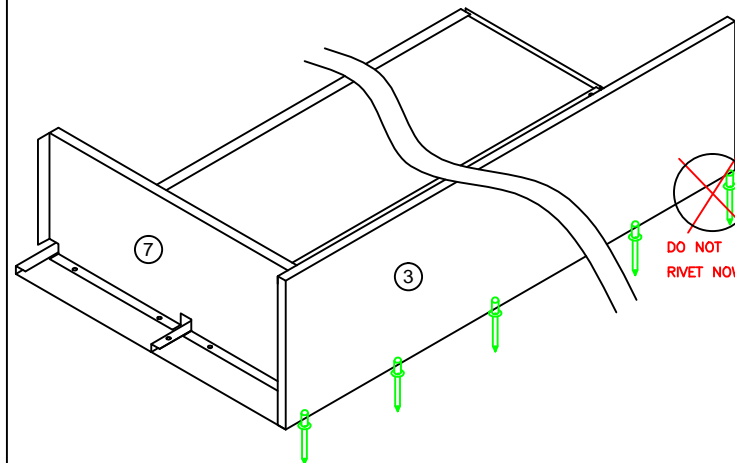

Assemble RH Side with RH back as shown and rivet from outside. **DO NOT** Rivet the topmost rivet which will be riveted along with TOP. Similarly Assemble LH Side.

STEP-4

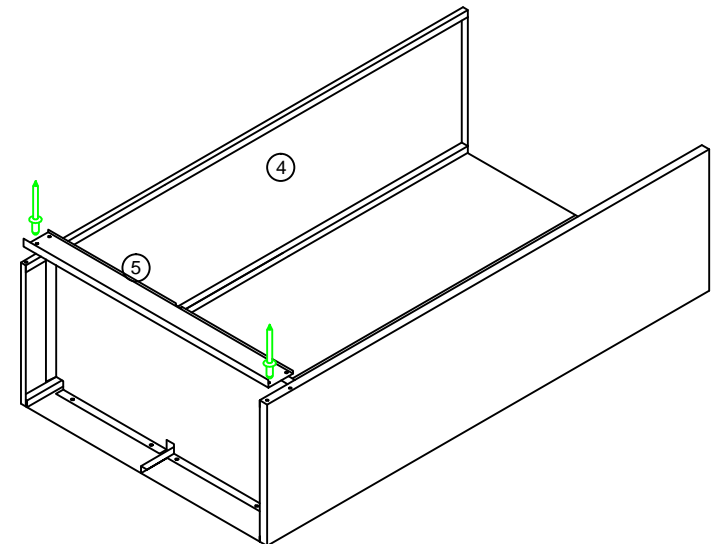

Assemble the Bottom channel as shown and Rivet with sides.

STEP-5

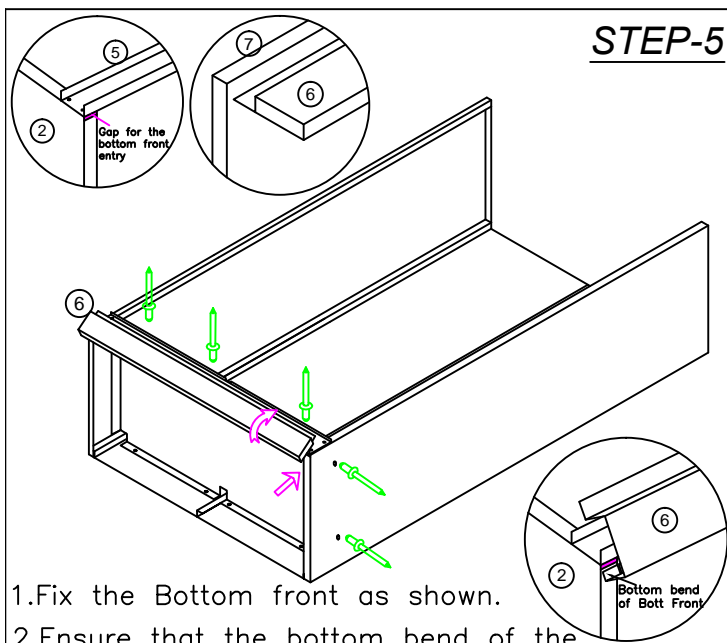

1. Fix the Bottom front as shown.
2. Ensure that the bottom bend of the bottom front will engage with the sides and the bottom channel as shown in the enlarged view.
3. Check that the Bottom tray comes above the bottom front and Rivet together.

STEP-6

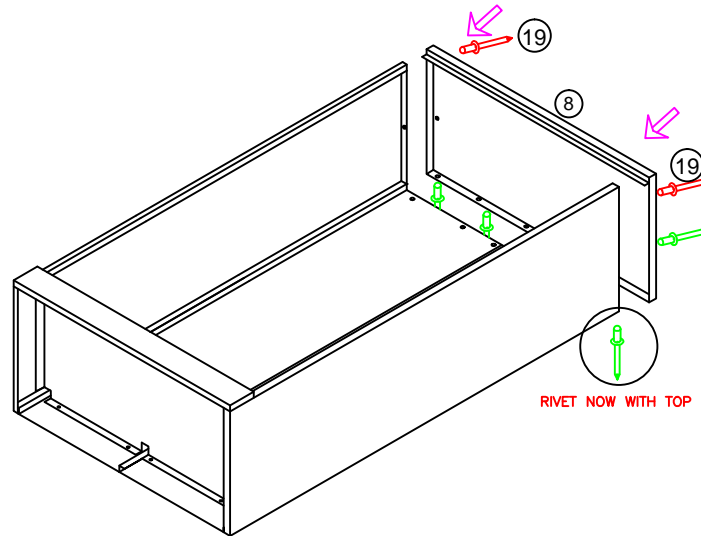

Assemble the top and rivet with Backs and sides as shown. Now the carcass is ready. please erect the carcass for doors fixing.

STEP-7

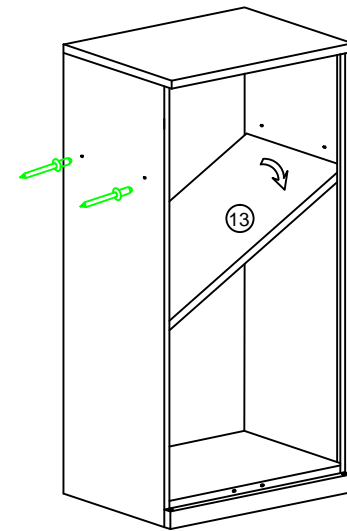

Assemble the Top shelf as shown and rivet with sides

STEP-8

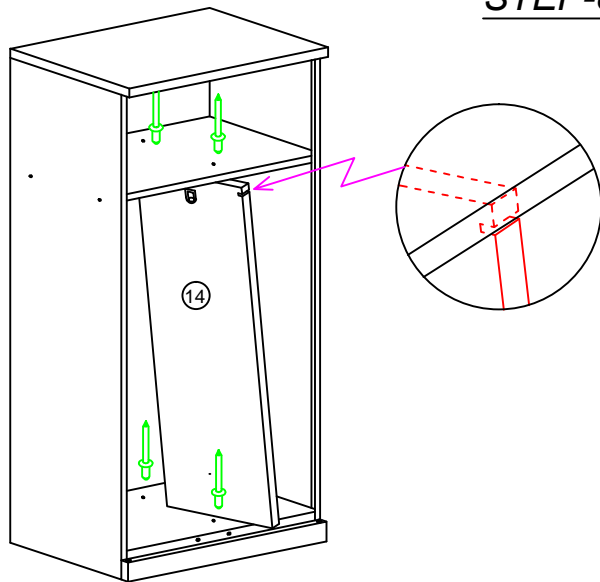

Assemble the Partition as shown and rivet with Top shelf and bottom tray. Ensure that the cut on the partition will engage in the Top shelf bend.

STEP-9

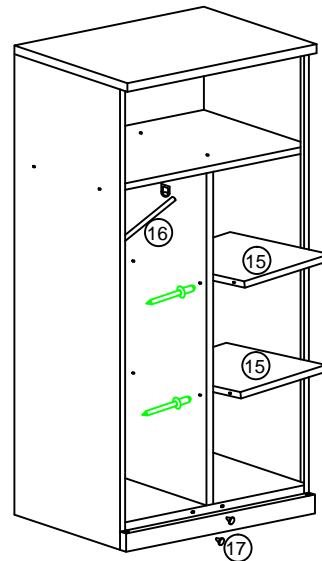

1. Now Assemble the two small shelves in RH side compartment as shown and rivet with side and partiton.
2. Fix the coat rail (hanger Rod) in LH side compartment as shown.
3. Fix the door stoppers

STEP-10

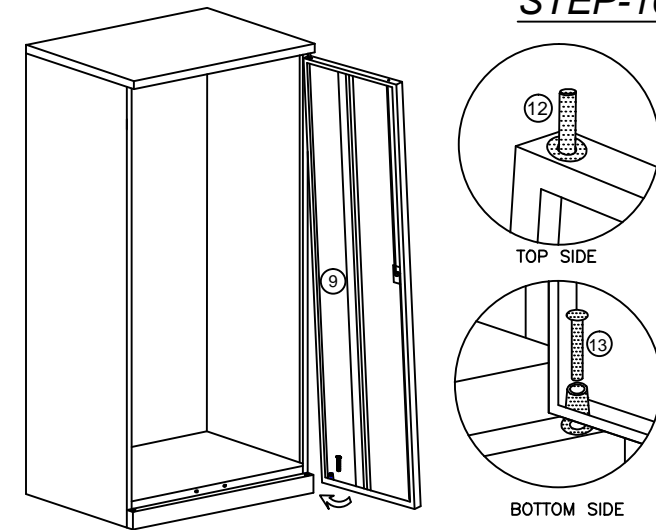

1. Insert the Top Hinge pin in the top Hinge Bush and fix the Door as shown in the drawing.
2. Position the Door on the Bottom front and then insert the bottom Hinge pin from top as shown.
3. Similarly fix the LH Door.