

Assembly instructions

NPM-SLEG

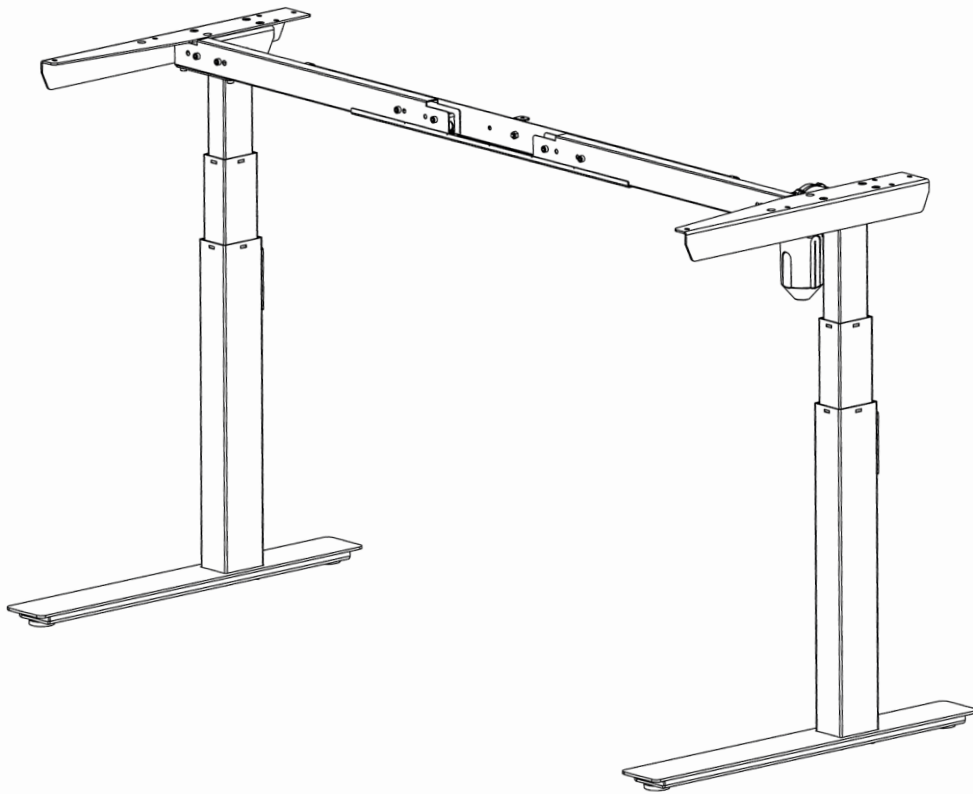

TABLE OF CONTENT

1. SAFETY AND WARNINGS
2. USAGE
3. SET UP AND INSTALLATION
4. OPERATION
5. MAINTENANCE AND DEFECTS
6. TECHNICAL DATA
7. PARTS
8. ASSEMBLY DIRECTIONS
- 8b. ACCESSORY ASSEMBLY DIRECTIONS
9. DECLARATION OF CONFORMITY

IMPORTANT NOTES!

Prior to installation, use and maintenance of the table frame, any installer and any user of the table must study this assembly and operation manual carefully, so as to gain a complete understanding of its contents.

1. SAFETY AND WARNINGS

This table complies with the prescribed safety regulations. Inappropriate use may cause damage to persons and table.

Please read the operation manual prior to using the table. It provides you with important information about safety, use, installation and maintenance of the table, and thus protecting you and your children and avoiding damage on the table.

Please guard this operation manual and pass it on to any future owner!

2. USAGE

- The electromotive, height-adjustable tables are designed for workstations in dry work environments only (0-40°C; 20-90% relative humidity). The table height is infinitely adjustable, so that it can be set to the most ergonomically suitable working level.
- They have not been designed for other purposes than those included in this manual, e.g. they are not to be used in areas of high humidity or dampness, nor for lifting people. Any other use is at one's own risk!
- **Do not crawl, lie or move around under the table frame, and do not sit or stand on the table frame.**
- **CHILDREN should only use the table when supervised by adults.**
- **Liability:** The manufacturer accepts under no circumstances warranty claims or liability claims for damages arising from improper use or handling of the table frame other than that described in this operation manual.

3. SET UP AND INSTALLATION

When the table has been assembled (see assembly directions in CHAPTER 8) the adjustable feet are installed so that the table is level and does not shift. Then the table is connected to the 100-240 VAC outlet and the table is ready for use.

- Make sure that no cables can get jammed.
- Place the table in a safe distance from window frames, radiators, furniture etc. so that people do not get stuck.
- Do not place any objects above 550 mm underneath the table.
- When moving the table after it has been assembled, the table top needs to be removed. The table CANNOT be lifted by the table top. The desk need to be lowered to minimum height before moving.



WARNING: FAILURE TO COMPLY WITH OR OBSERVE ALL ASSEMBLY, SAFETY AND OPERATION INSTRUCTIONS AND WARNINGS REGARDING THE USE OF THIS PRODUCT MAY RESULT IN SERIOUS BODILY INJURY.

4. OPERATION

UP/DOWN operation:

Push the buttons for operation up or down



5. MAINTENANCE AND DEFECTS

- The table does not require any maintenance by usage as described in chapter 2 in the directions for use.
- The table is only to be maintained with a damp cloth.
- In the event of the occurrence of jarring sounds during operation, STOP using the table and please contact the dealer.

6. TECHNICAL DATA

Frame, materials:	Steel, powder lacquered
Weights (frame):	32 kg
Width (top):	1500/1800 mm
Depth (top):	700 mm
Height (frame):	630 - 1230 mm
V (speed):	~ 32 mm/sec., depends on load.
F_{MAX} = Max. load:	100 kg (on frame)
Duty cycle:	10% by 50% of max. load on frame or max. 2 min. continuously
Operation:	Micro switches
Voltage:	100-240 VAC 50/60 Hz
Standby Consumption:	<0,15 Watt

Above specifications may vary depending on local temperature, humidity and input voltage.

7. PARTS See page 4.

8. ASSEMBLY DIRECTIONS See pages 6-8.

9. DECLARATION OF CONFORMITY

We hereby declare, under our sole responsibility that the following products:

- Sit and stand table product type NPM-SLEG

is in accordance with:

- Directive 2006/42/EF of The European Parliament and of the Council of 17 May 2006 on machinery and on changes of directive 95/16/EF

With reference to the above please be aware that:

- the sit and stand table is considered a machine and
- the sit and stand table may not be used until it has been assembled and installed according to the instructions.

7. Parts

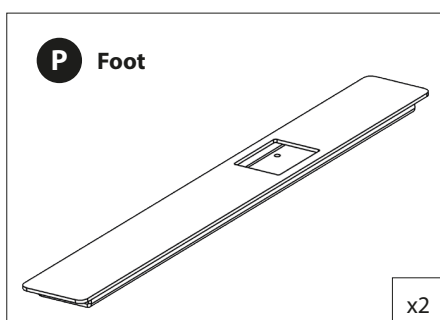
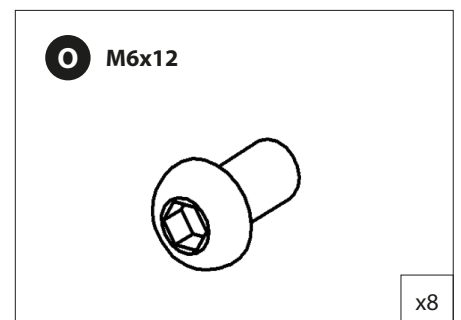
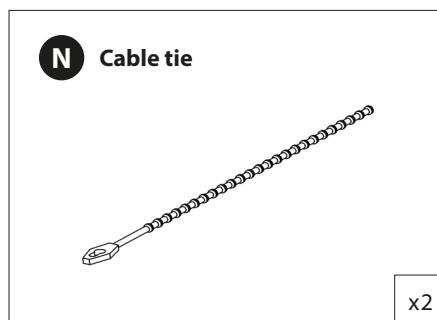
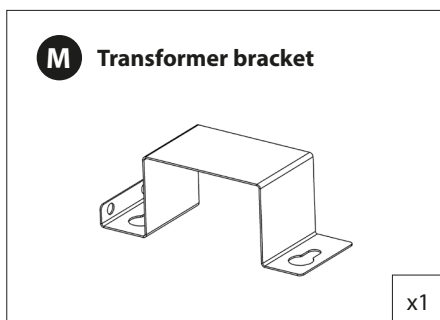
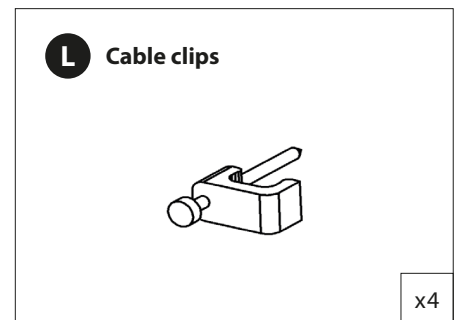
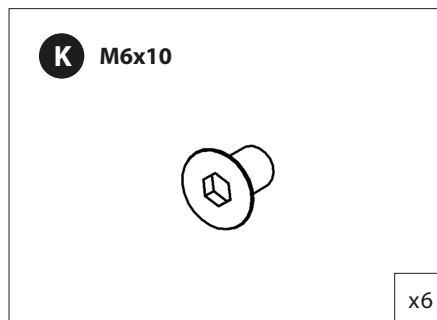
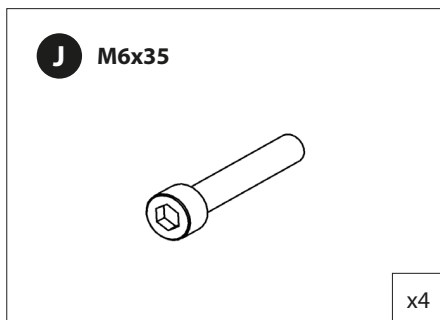
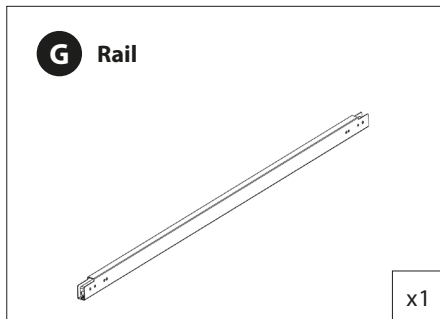
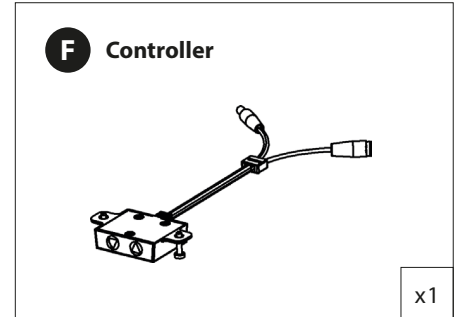
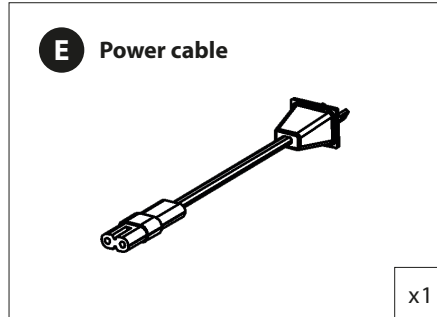
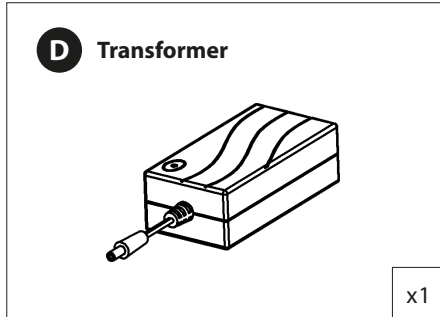
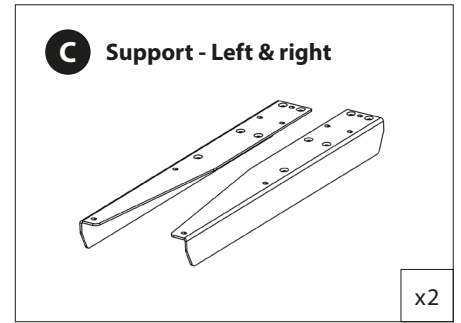
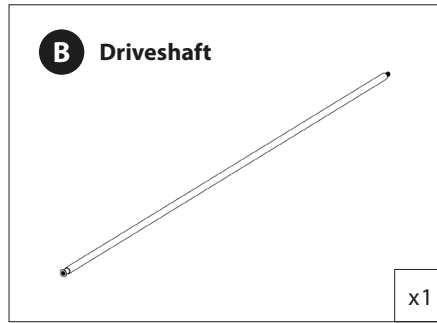
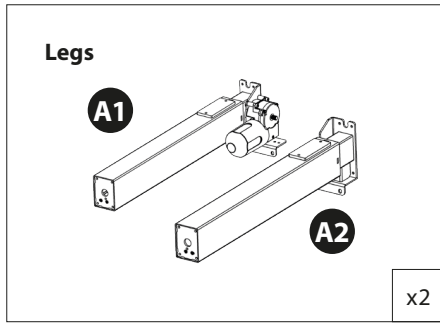

8. Assembly instructions // Select the width of your frame

Frame width 1420 mm

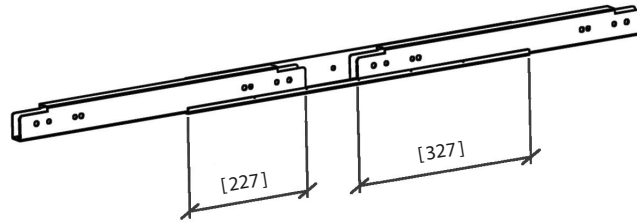

Frame width 1720 mm

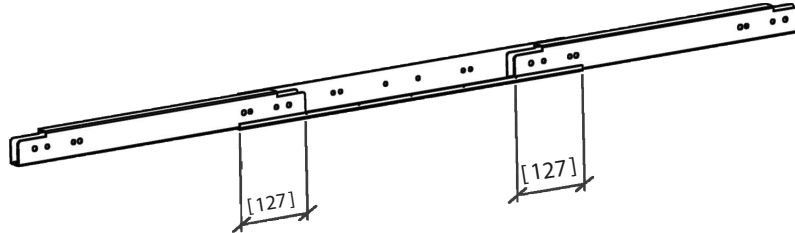

8. Assembly instructions // Attach top beam with appropriate screws

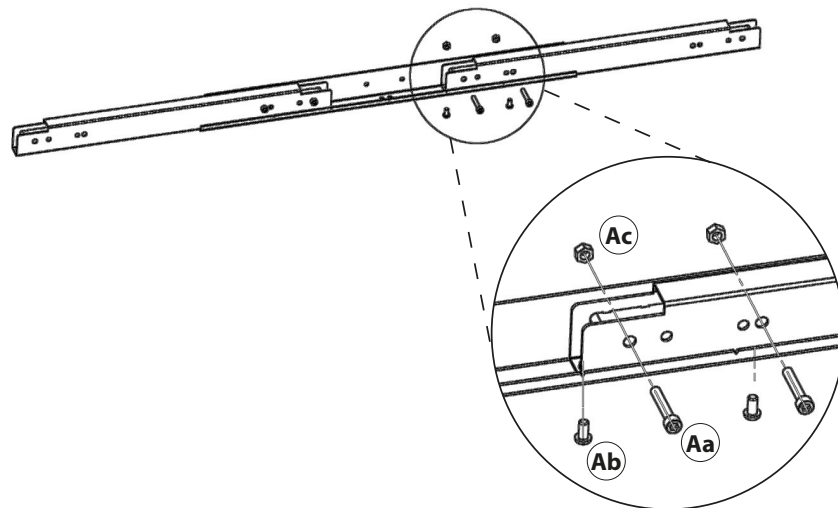

8. Assembly instructions // Mount the top bracket

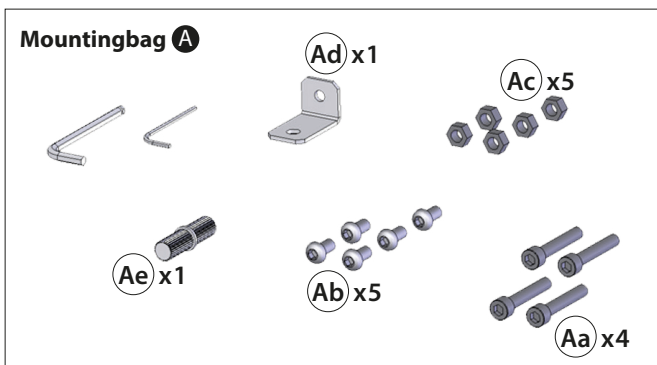
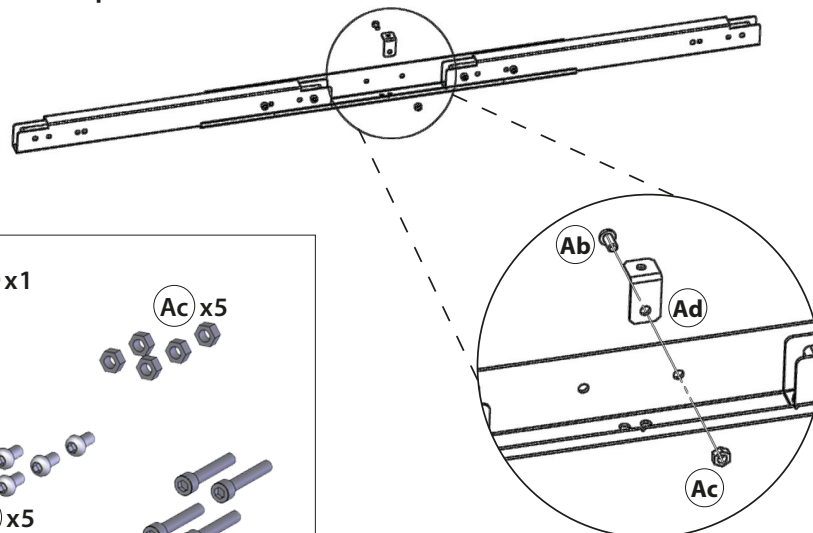

8. Assembly instructions

1.

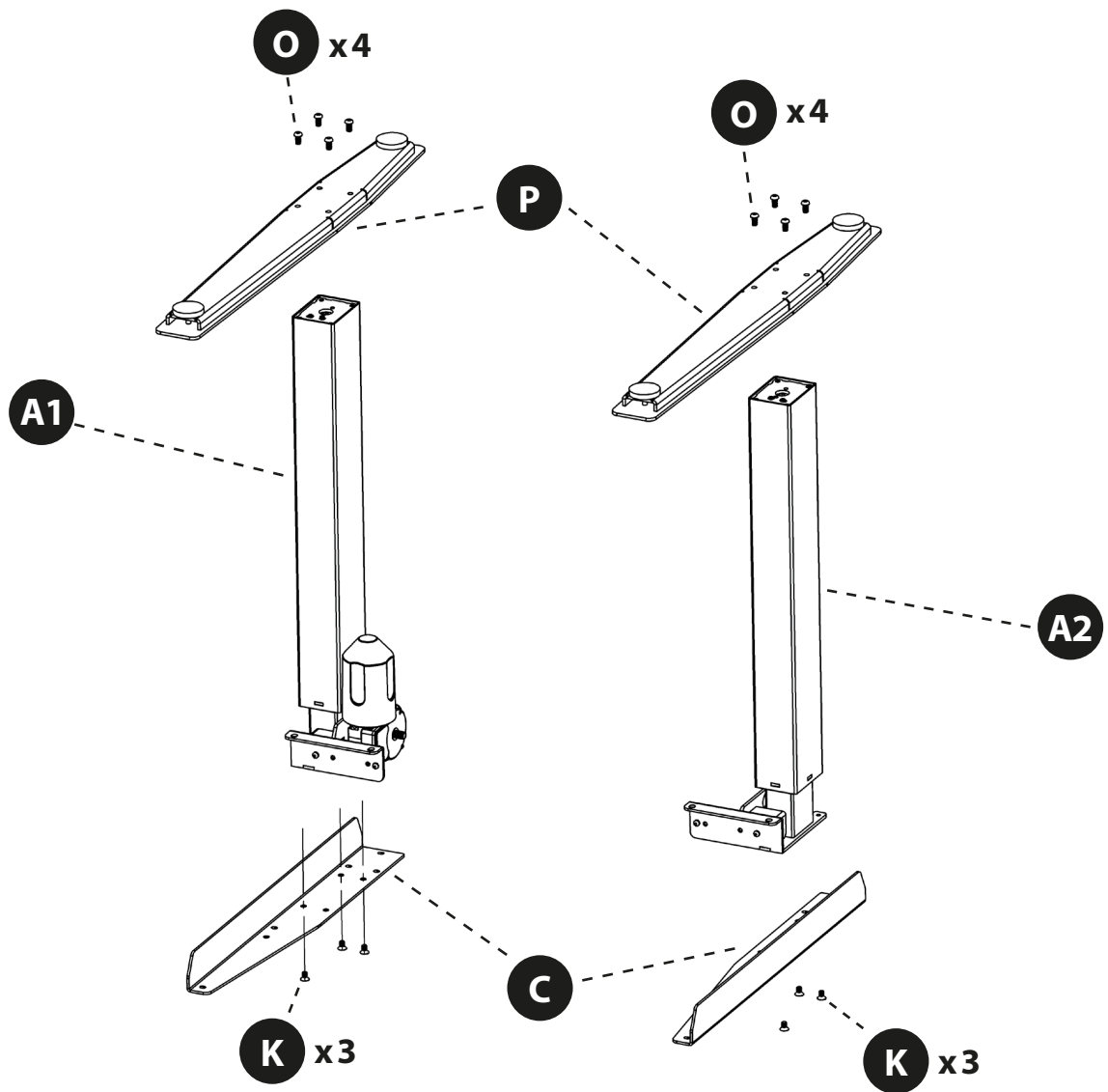

2.

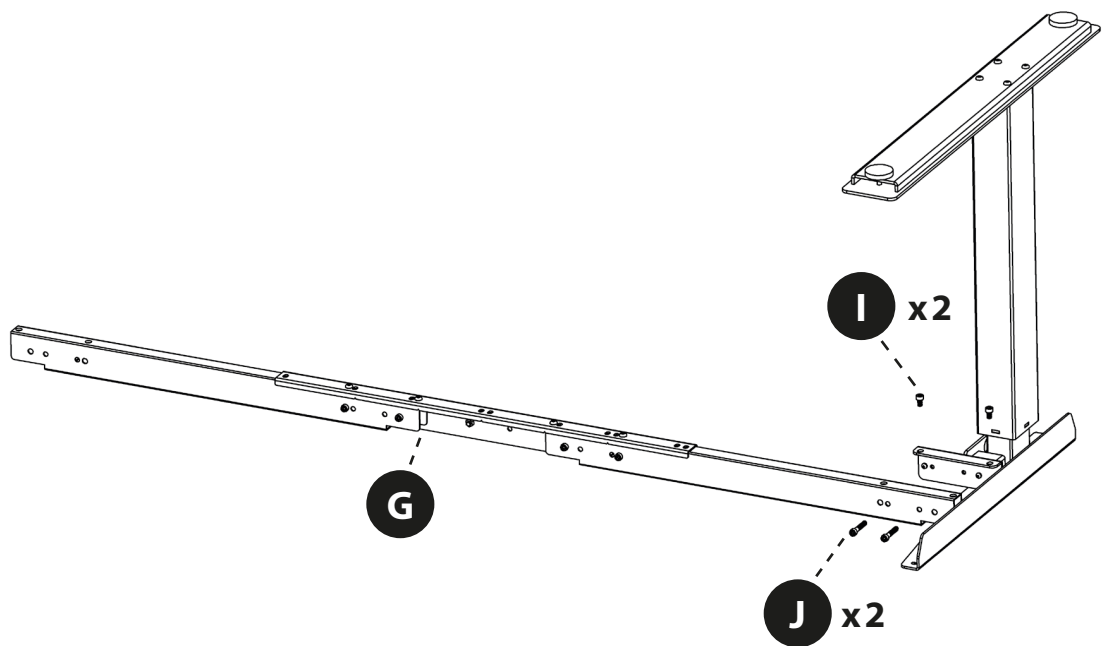

3.

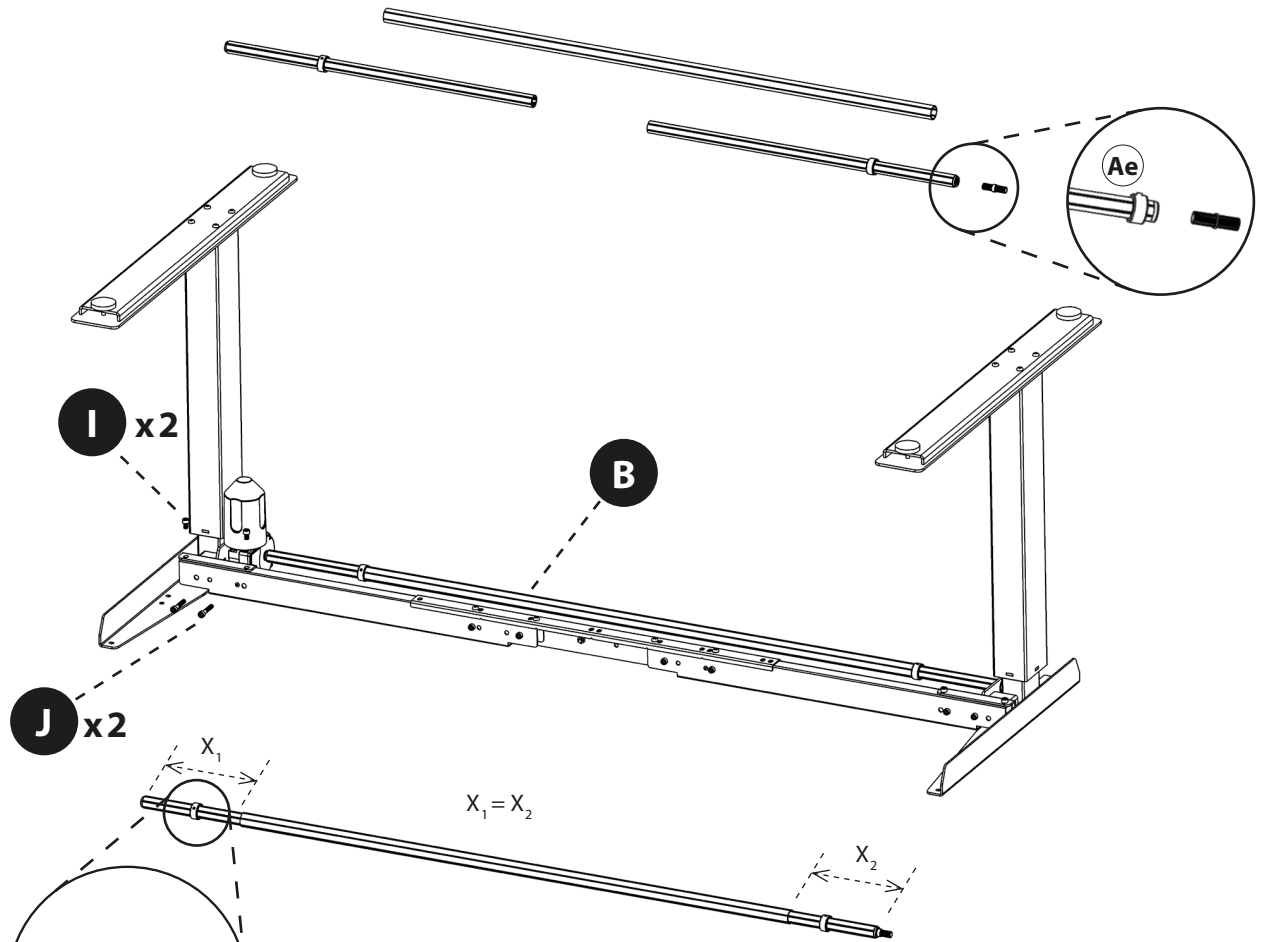

4.

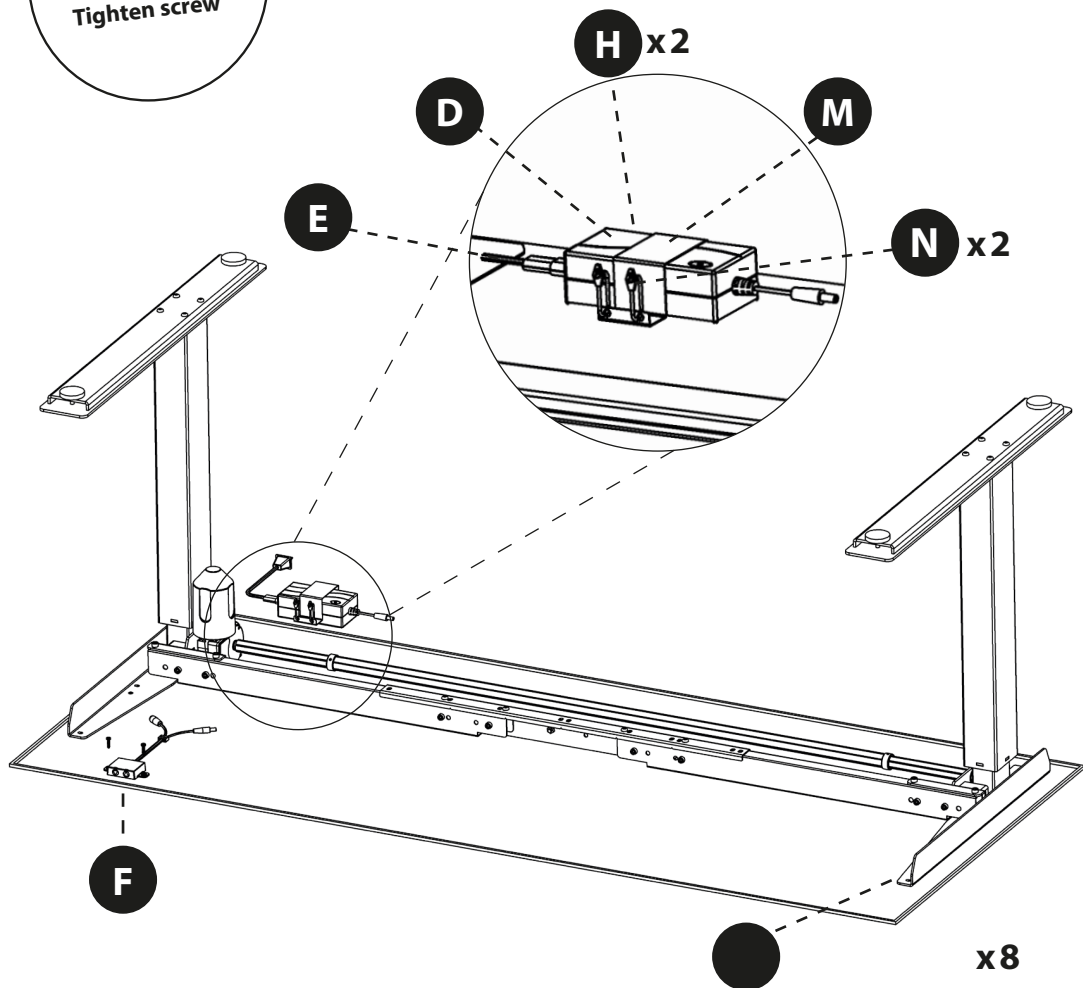

Components position and wiring

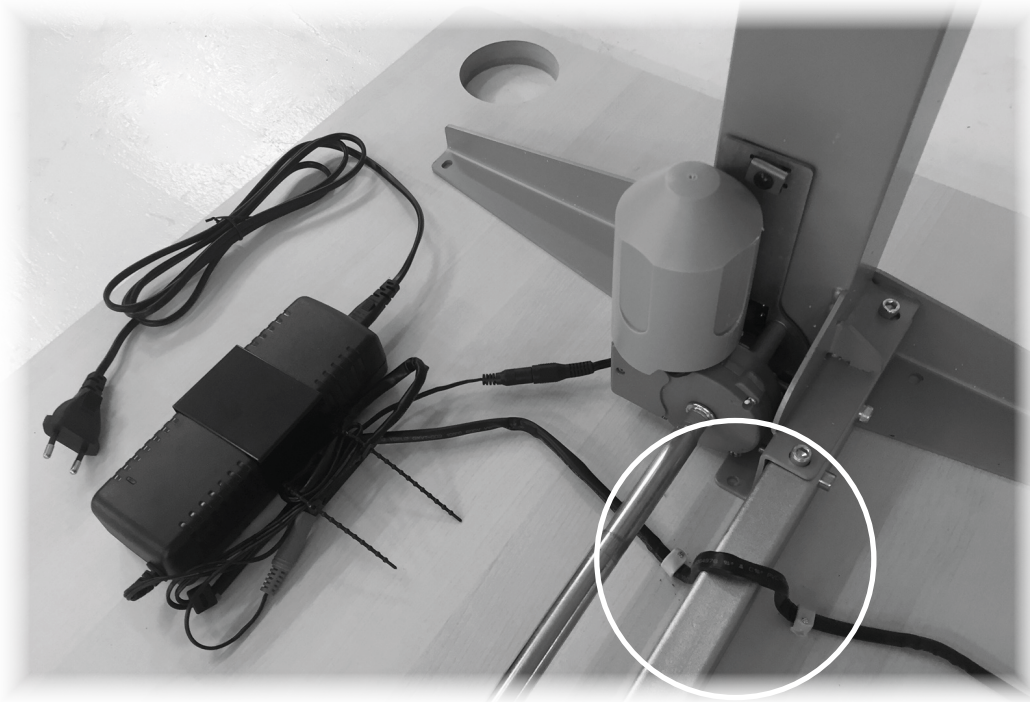
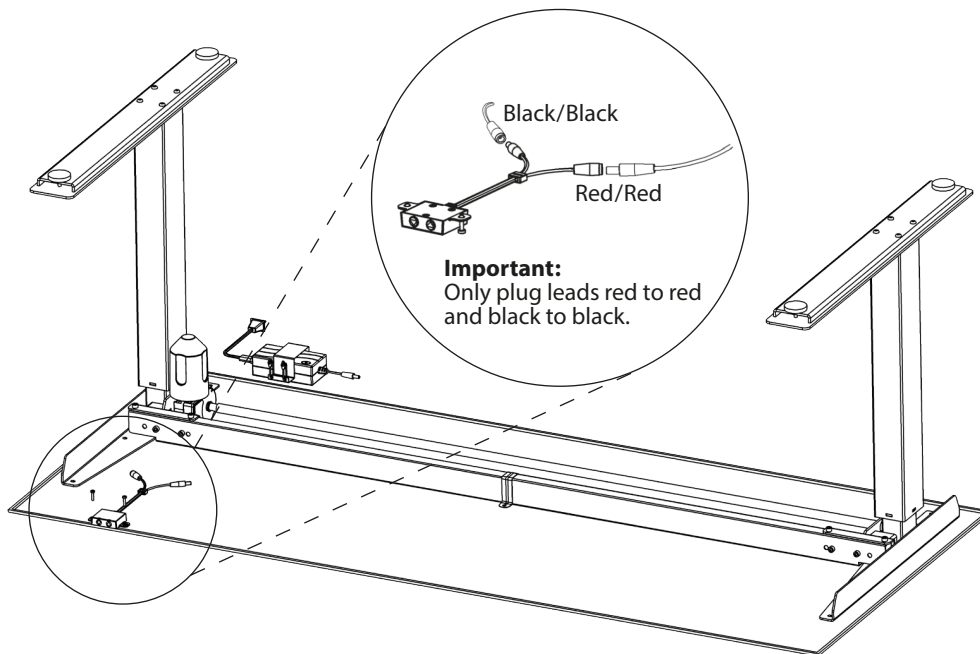

To ensure correct up and down operation of the desk frame it has to be fitted with a table top or applied a similar weight. Without a table top fitted, the desk frame may not operate in the downward direction.