

Agile Flip

Assembly Instructions

Agile Flip

Components List

Components

		QTY	Part No.
1	Steel Leg Flip Table Frame	x2	AGFLIP..
2	Agile Flip Mechanism	x2	AGFLIPMECH
3	Main & Pull Rail	x1	AGFLRAIL...
4	Flip Rail Bracket	x1	
5	Worktop	x1	

Screws

		QTY
6	Screw	x4
7	Worktop Screw	x12
8	Washer & Screw	x2

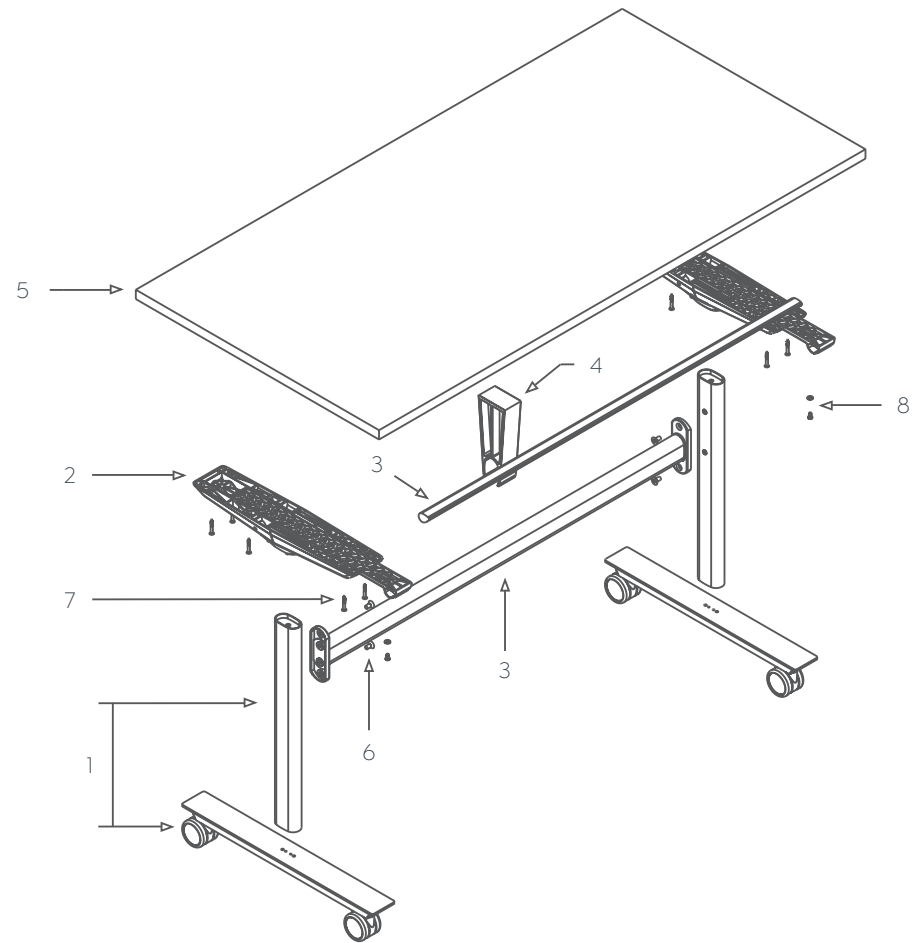

STEP 1:

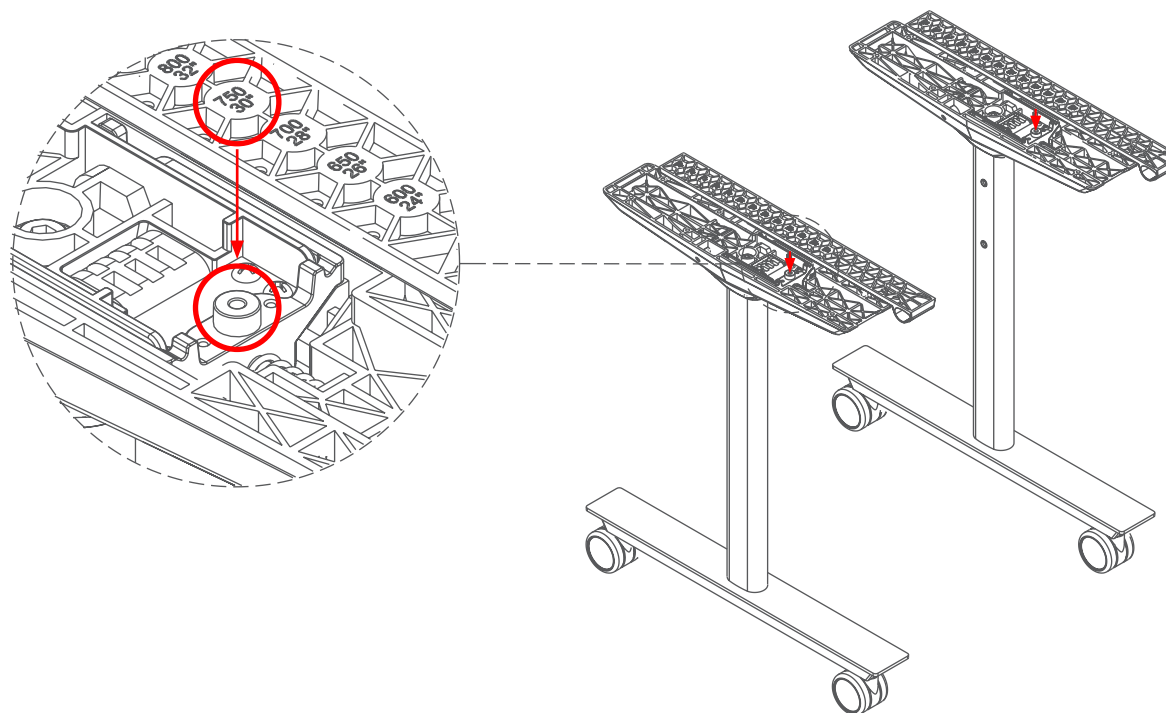

Fit the pull bar to the top of the mechanism. Find the correct work top depth on the guide, and place it down over the locator pin.

Agile Flip

Assembly Instructions

STEP 2:

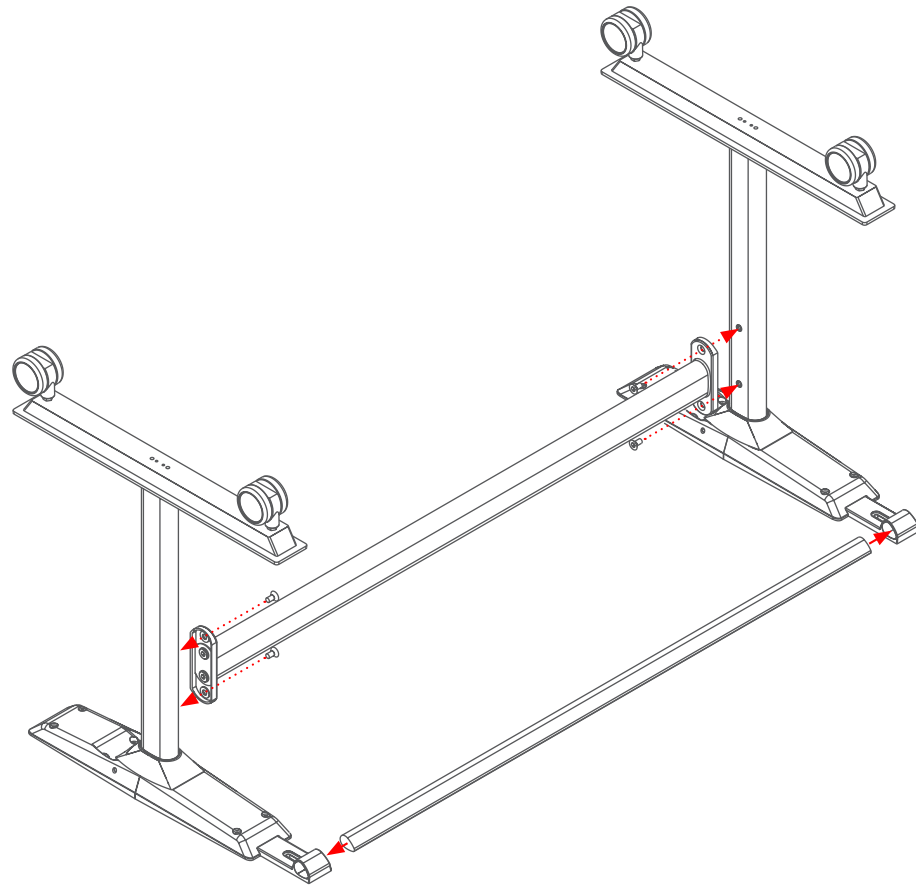
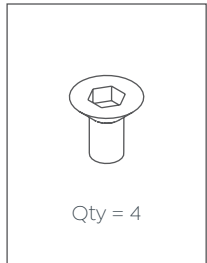

STEP 3:

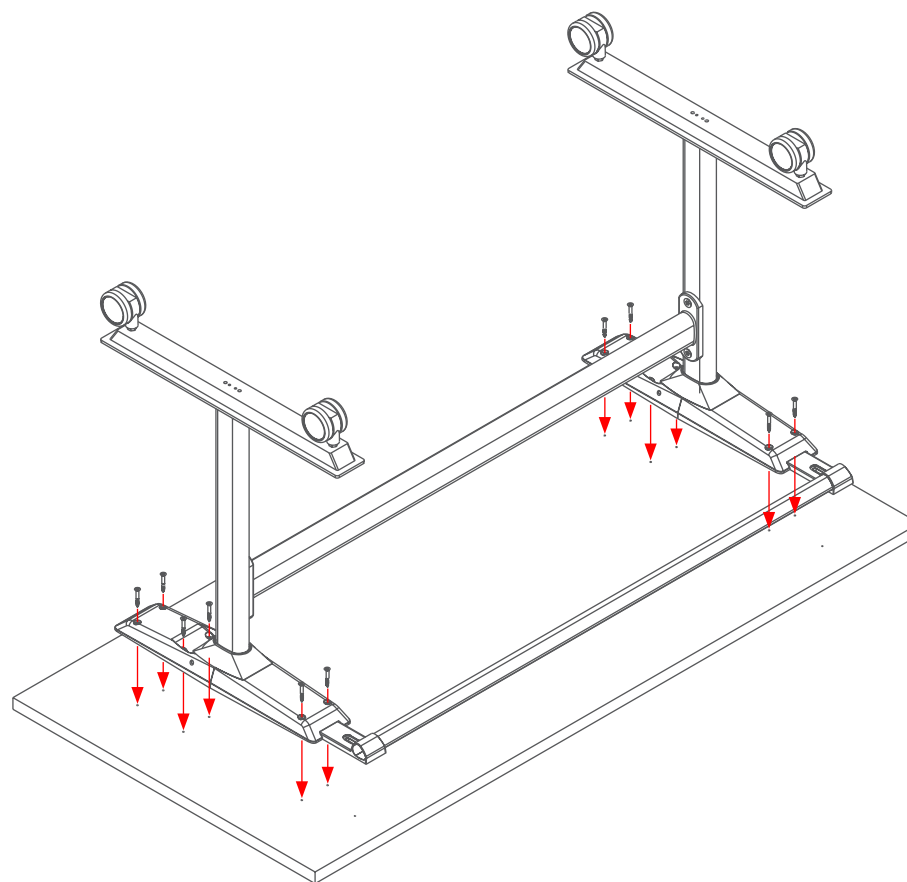
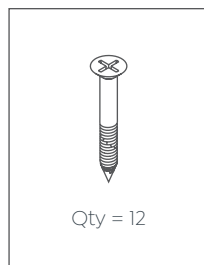

Agile Flip

Assembly Instructions

STEP 4:

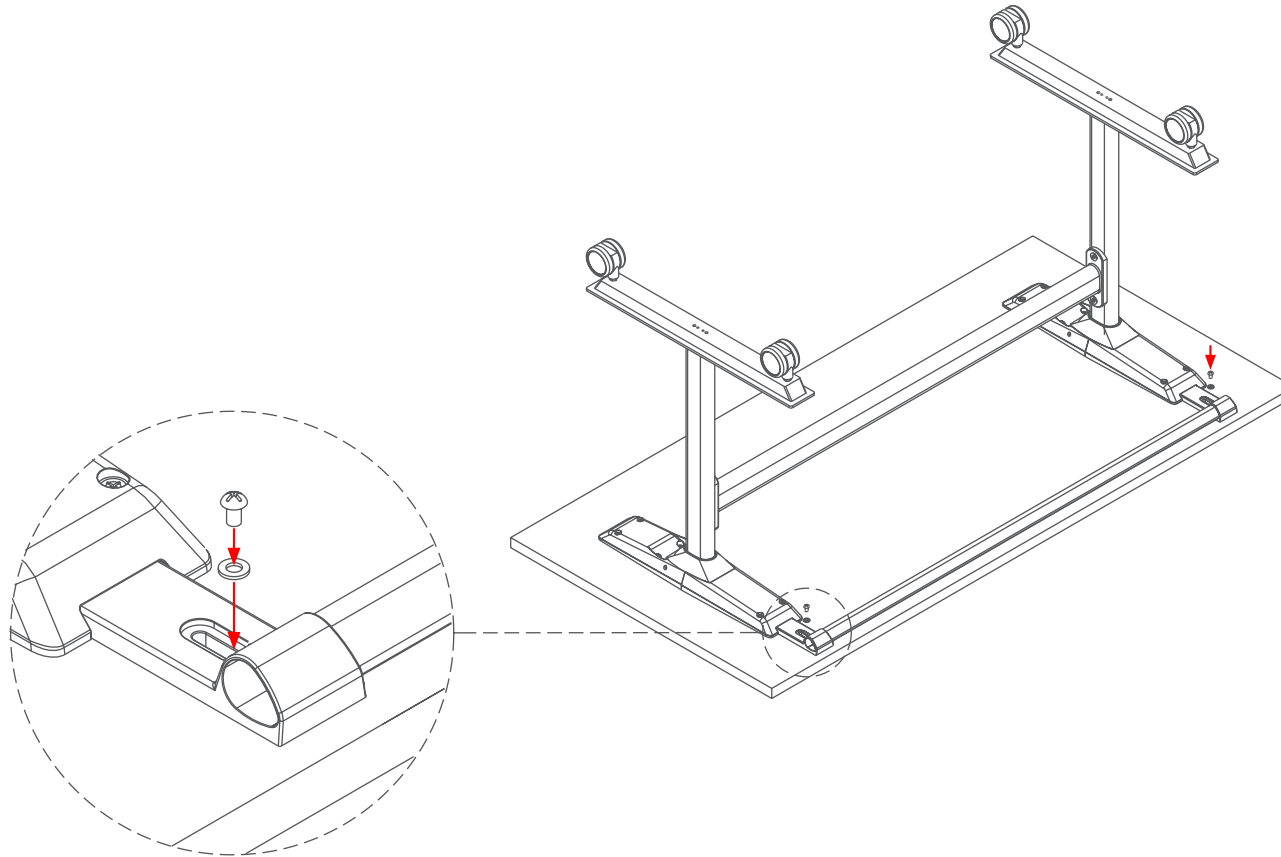
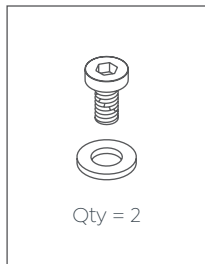

For tables with a work top deeper than 700mm, attach the pull bar to the work top using the screw & washer supplied. Leave the screw a single turn from tight so the pull bar will operate smoothly.

STEP 5:

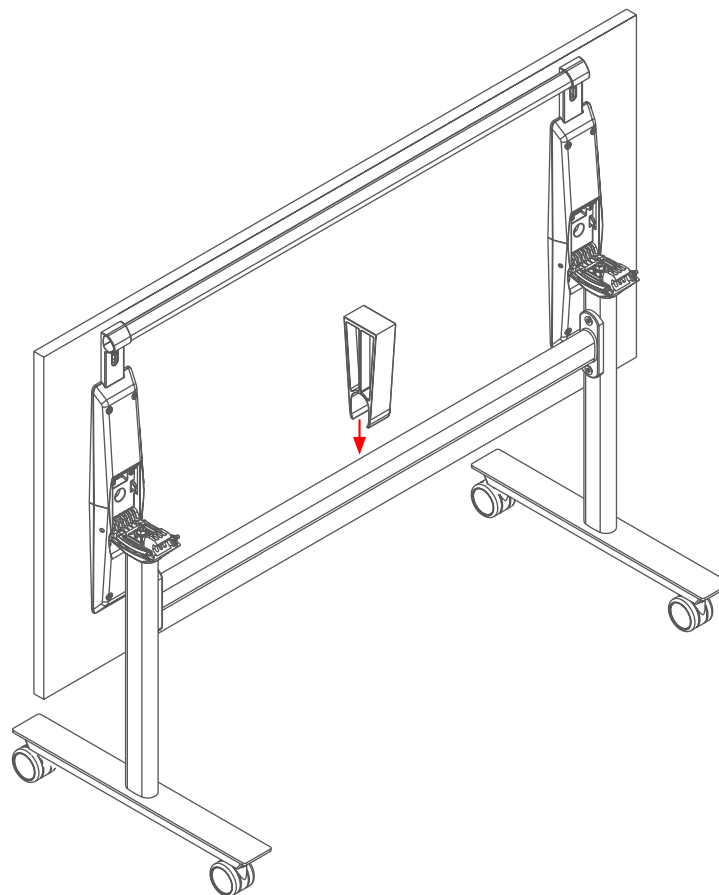

Agile Flip

Assembly Instructions

Complete:

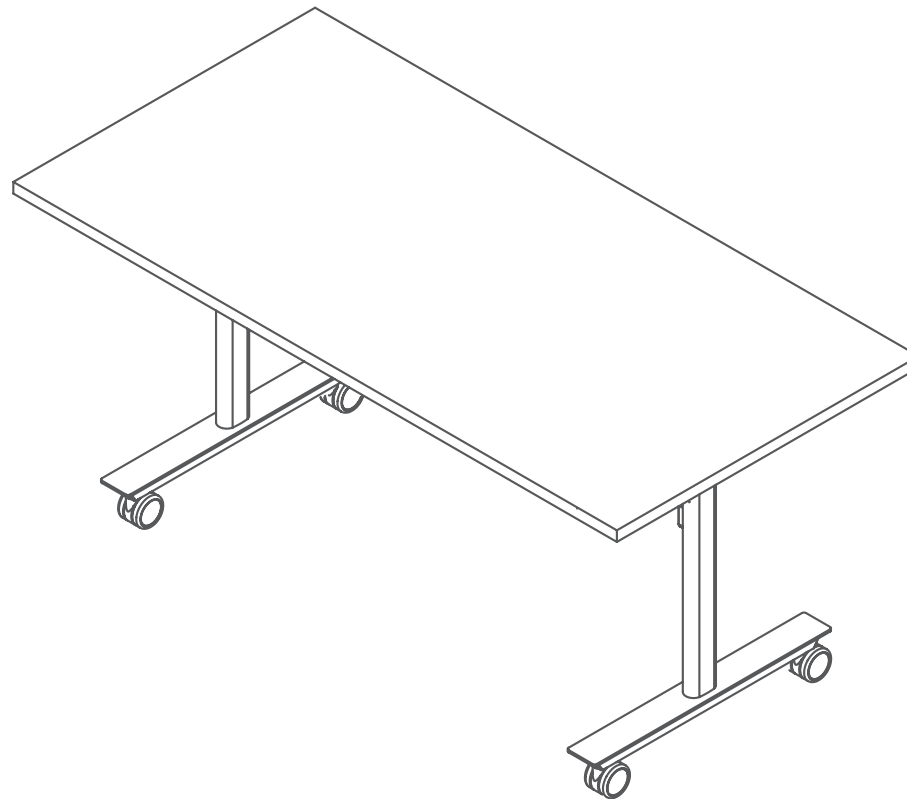

Width - 600mm

	A	B	C
1200mm	796	96	N/A
1500mm	1096	96	N/A
1800mm	1396	96	N/A

Width - 750mm

	A	B	C
1200mm	796	171	100
1500mm	1096	171	100
1800mm	1396	171	100

Width - 900mm

	A	B	C
1200mm	796	246	175
1500mm	1096	246	175
1800mm	1396	246	175

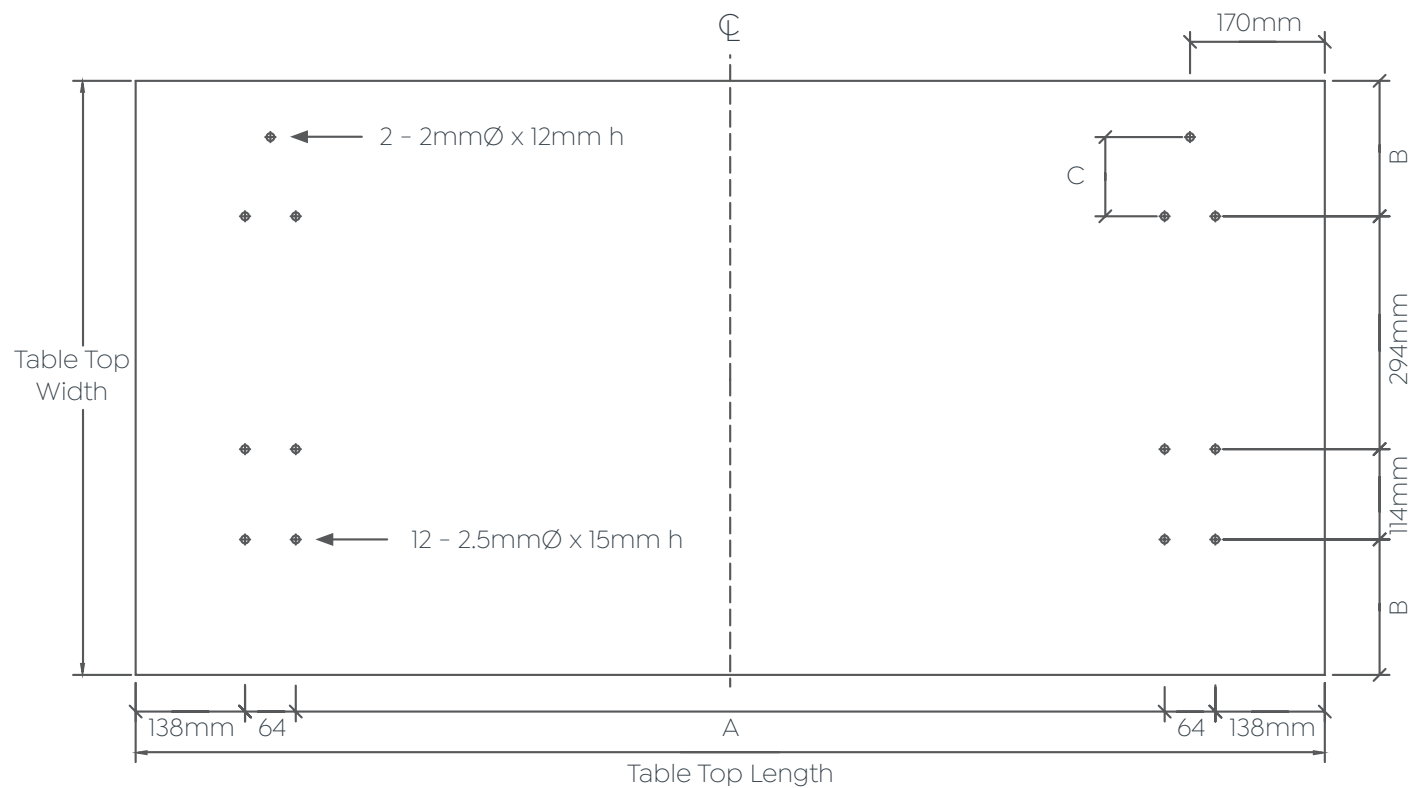

Agile Flip

Assembly Instructions

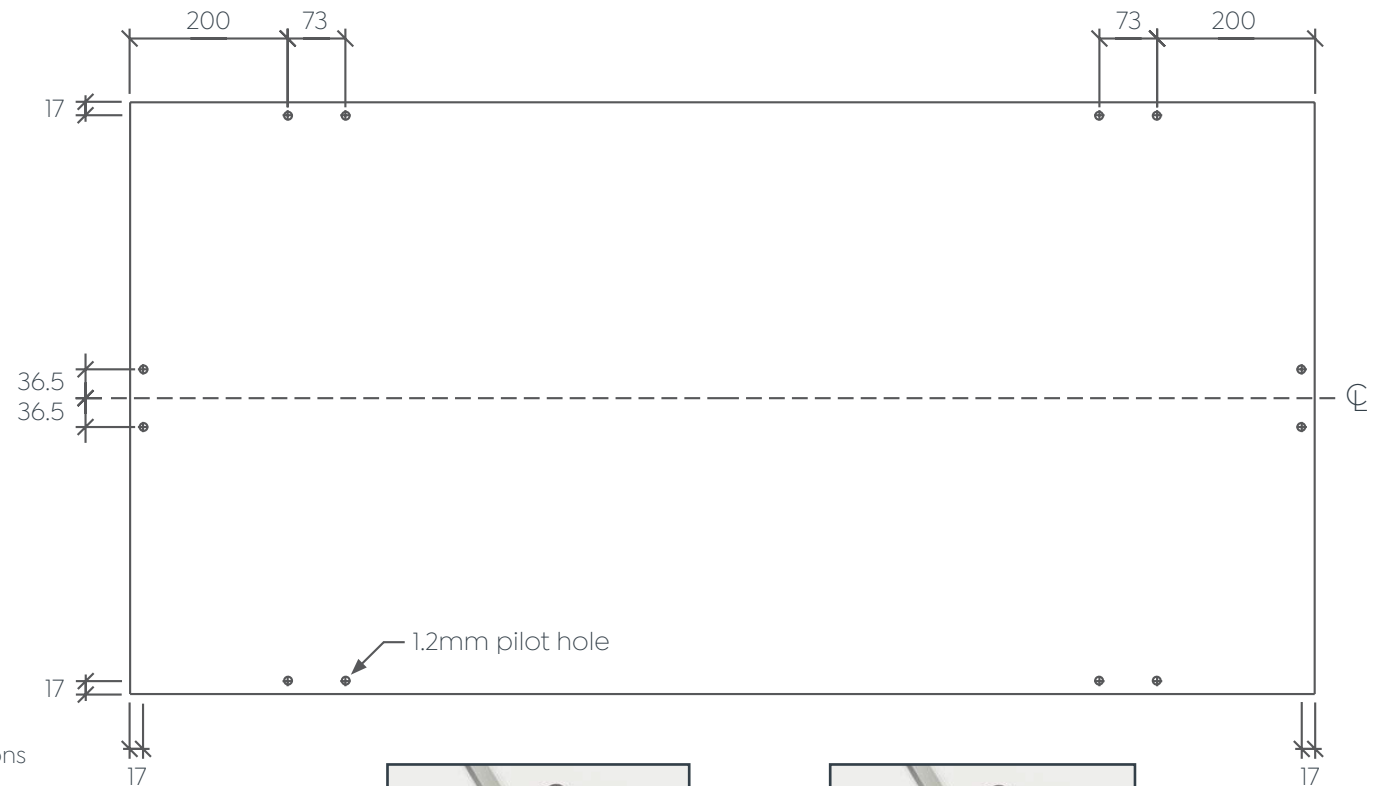

Care Instructions:

Please visit our website for Care & Maintenance instructions
www.olgoffice.com



Locked connector link



Unlocked connector link