



# PLANTATION

Assembly Instructions

# Plantation

Assembly Instructions - Meeting Table 4 Leg

---





**STEP 1:** Assemble 2x end leg frames to the legs. Total 6 x M12 per leg.



**STEP 2:** Assemble the rail receivers to the crossbar.

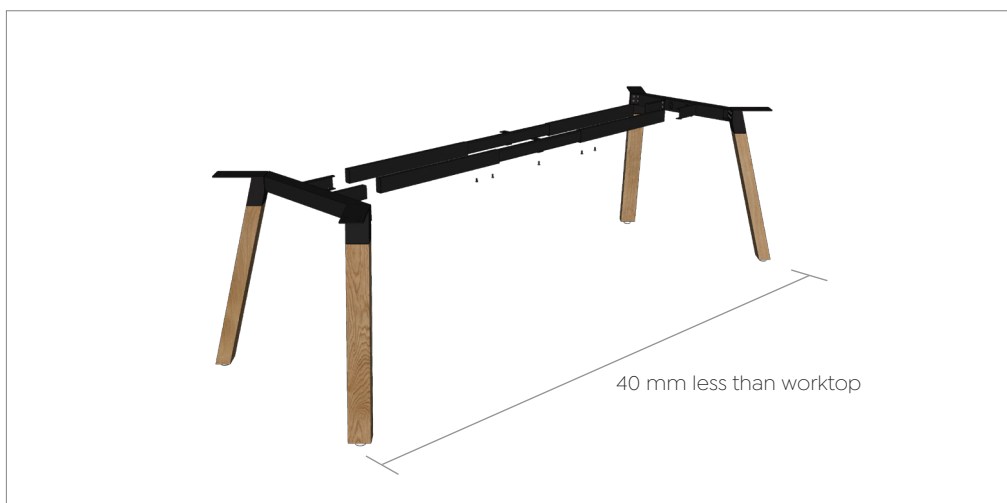

**STEP 3:** Assemble the rails to the end legs and set rail length.



**STEP 4:** Fix worktop to frame using 4 x 23mm screw per leg, 1 x 23mm screw per rail.

# Plantation

Assembly Instructions - Meeting Table 6 Leg

---



# Plantation

## Assembly Instructions – Meeting Table 6 Leg



**STEP 1:** Assemble 2x end leg frames to the legs.  
Total 6 x M12 per leg.

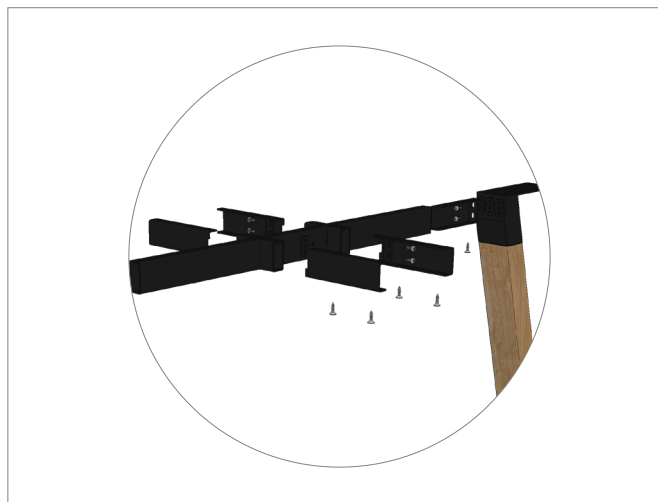

**STEP 2:** Assemble the rail receivers to the crossbar.



**STEP 3:** Assemble the mid leg using bolts provided in the spreader bar kit. Mount the rail to the centre mounting point.

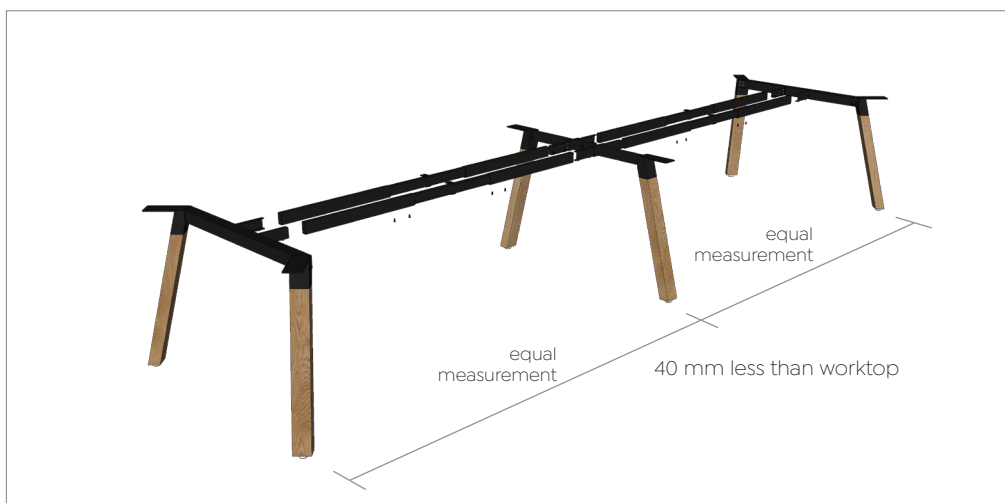

**STEP 4:** Assemble the rails to the end legs and set rail length.



**STEP 5:** Fix worktop to frame using 4 x 23mm screw per leg, 1 x 23mm screw per rail.



# Plantation

Extendable Rails

---

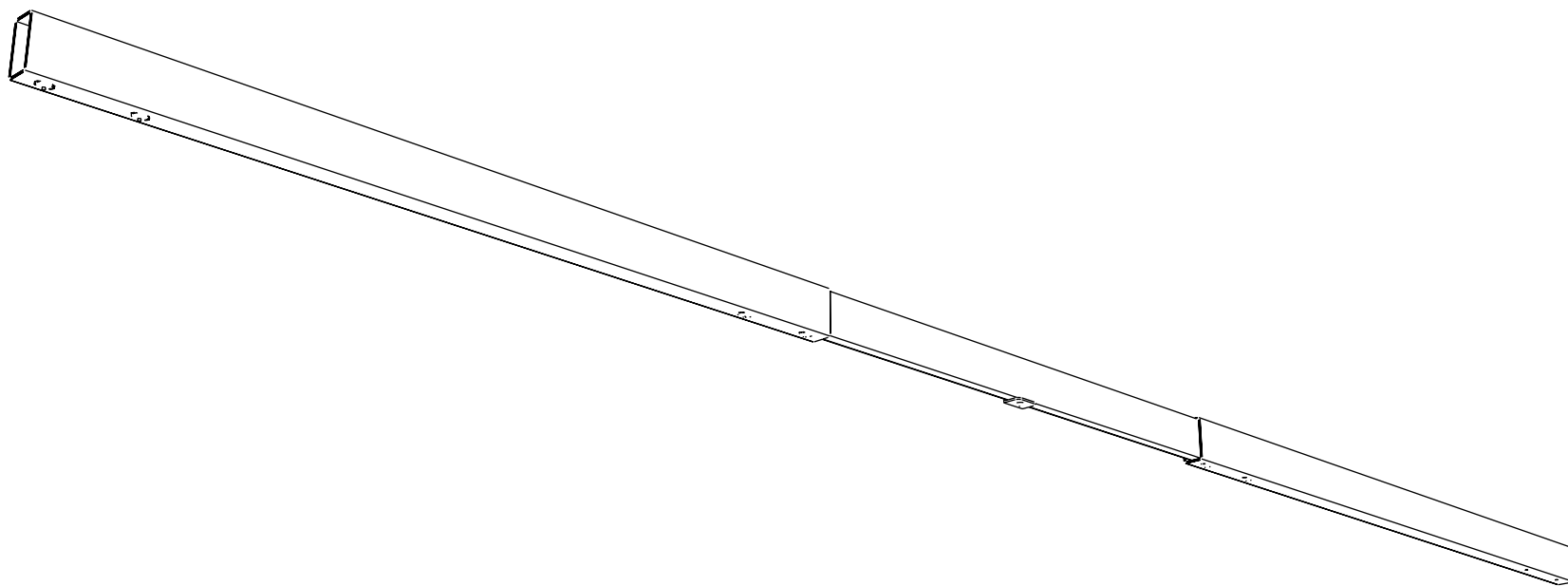

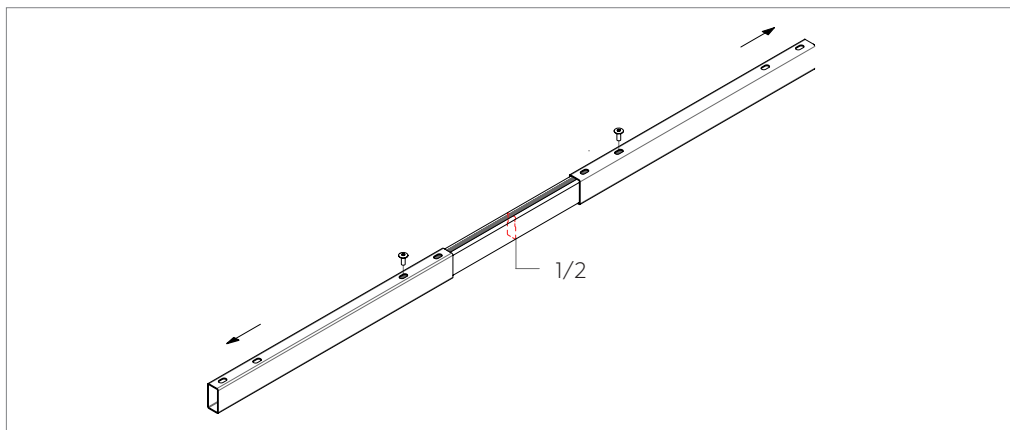

**STEP 1:** Unscrew end rails and remove.

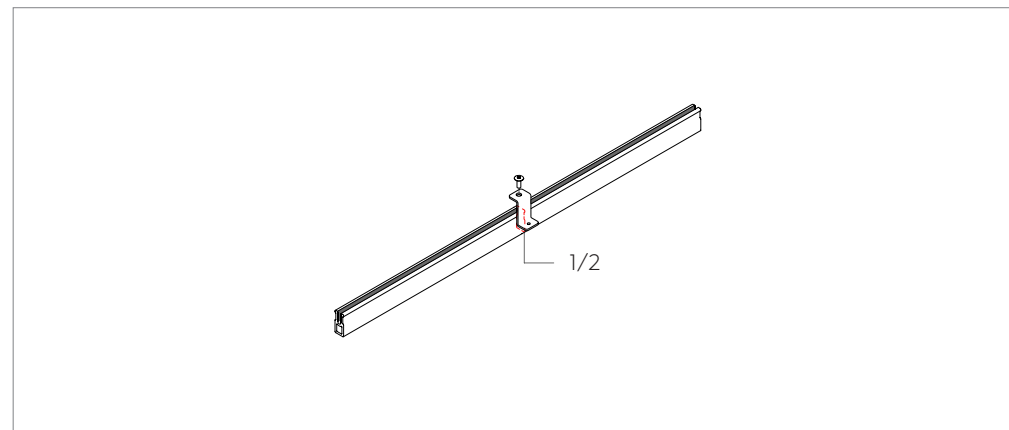

**STEP 2:** Find the middle point of the center rail and screw the bracket.

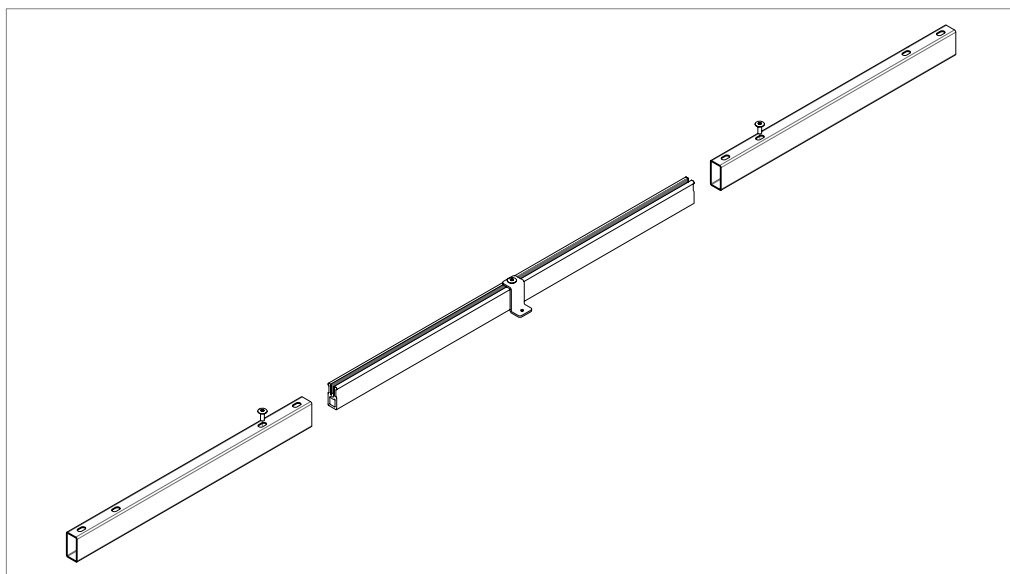

**STEP 3:** Use the center as reference to position both ends back into the center rail symmetrically.

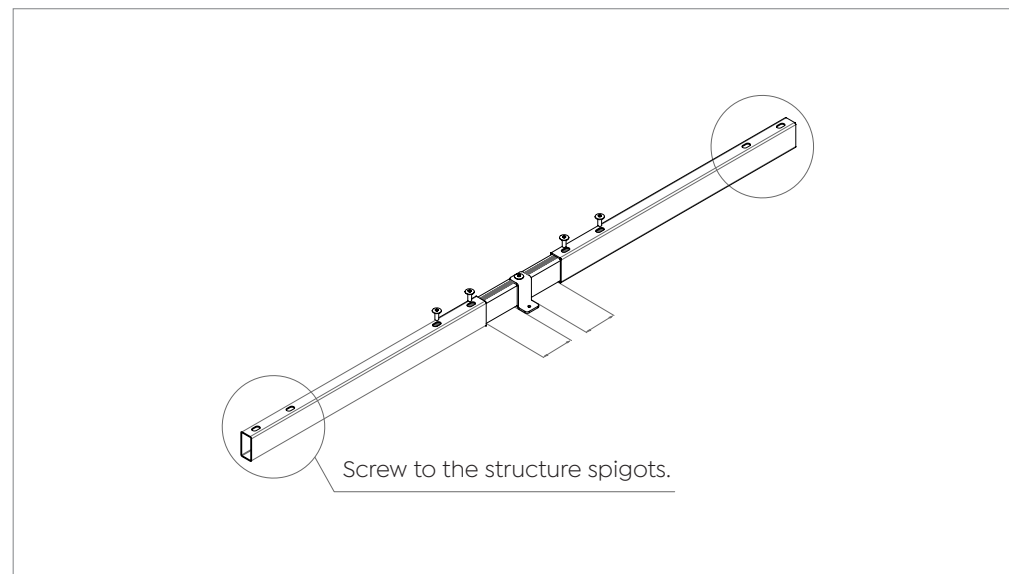

**STEP 4:** Screw the end rails to the center rail once achieved the desired length.



