



AgileMotion⁺ Electric Desk.

Product **Specifications**



AgileMotion+ Electric Desk.

AgileMotion+ is a fully optioned electric height programmable desking system, designed for modern, premium office spaces.

The system also integrates seamlessly with the single workstations and back to back desks, and can be further enhanced with fabric privacy panels, floor mounted Studio50 or AcoustiQ screens, monitor arms and personal storage units.

Available in single sided, double sided, 90° and 120° designs, the Agile+ electric desking system can be fitted with a variety of cable management options and multiple accessories...

Key Features

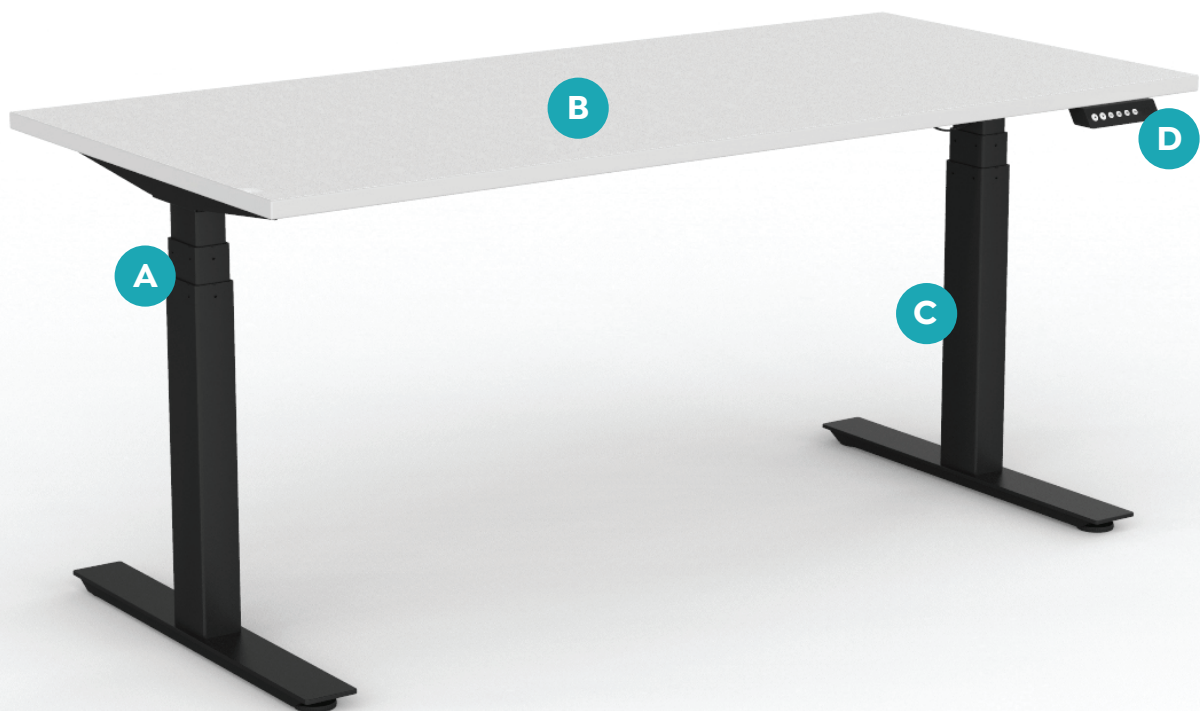

A. Height Adjustment

3 x Column height adjustment from sitting height - 635mm to full standing height - 1290mm.

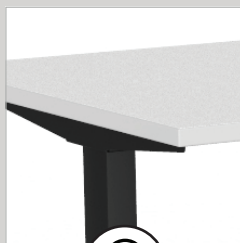

C. E0 Grade Worktop

Commercial grade 25mm melamine worktop constructed with zero formaldehyde.



B. Strong & Durable

Frame is constructed from 2mm Steel for extra strength and stability.

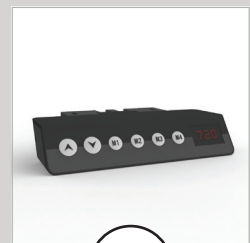

D. Electronic Handset

LED display handset with 4 x programmable memory presets.



AgileMotion+ single sided desk with Urban Mesh chrome base seating.

AgileMotion+ Electric Desk.

In Detail



Fast Assembly

Fast to assemble - rails come pre-fitted to the legs where possible.



Anti-Collision

Protect office equipment against damage with the built-in anti-collision software.



Quiet Motor Operation

Motors are concealed in each leg and only 40db while in operation.



Strong Mechanism

Electric double motor and premium materials results in a weight rating of 160kg when distributed evenly.



Precision Memory

4 point memory control, programmable to restrict min/max height and also to set anti-collision sensitivity.

Screen Options

Multiple screen bracket options available to support cable trays & screens with power and data.

Worktop

Available in White and New Oak

E0 Grade Worktop

Highest environmental rating available

Electronic Handset

4 Memory handset with LED display

Very Quiet

Only 40db noise while adjusting

Fast Assembly
Rails come pre-fitted to the legs

Strength

160kg weight rating (evenly distributed)
90 x 60mm 2mm steel tubing frame

10 Year Warranty
Best in it's class

Sturdy Feet

Flat foot design with leveling adjustment

Electric Double Motor

Height range: 635-1290 mm (incl. worktop)
Adjustment speed: 30 mm/s



* Refer to page 8 for Ratings & Certifications details.

AgileMotion+ Electric Desk.

Optional Upgrades



AgileMotion+ Single Sided Desk
Black Frame with New Oak Worktop
White frame also available



AgileMotion+ Double Sided Desk
Black Frame with New Oak Worktop
White fFrame & Worktop also available



AgileMotion+ Single Sided Desk White Frame
& Worktop with Cable Management
Tray and Studio50 Hung Screen
AcustiQ Screens also available



AgileMotion+ 90° Single Sided Desk
White Frame with New Oak Worktop
Black frame also available

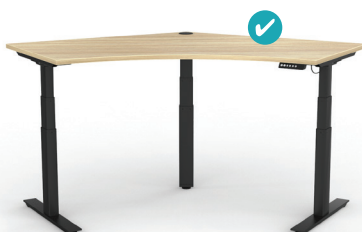

AgileMotion+ 120° Single Sided Desk
Black Frame with New Oak Worktop
White frame also available

Mellamine Worktop Colour Options



New Oak



White

Steel Frame Colour Options



Black



White



Studio50
Screens are
Australian
Made.

Breathe

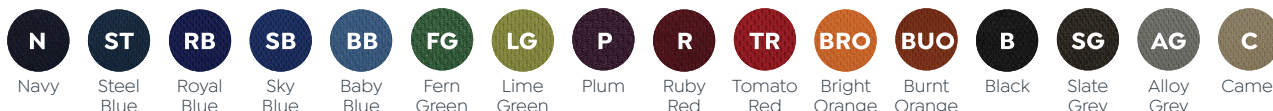

Splice



AcustiQ Screen Colour Options



AgileMotion+ Electric Desk.

Dimension Specifications

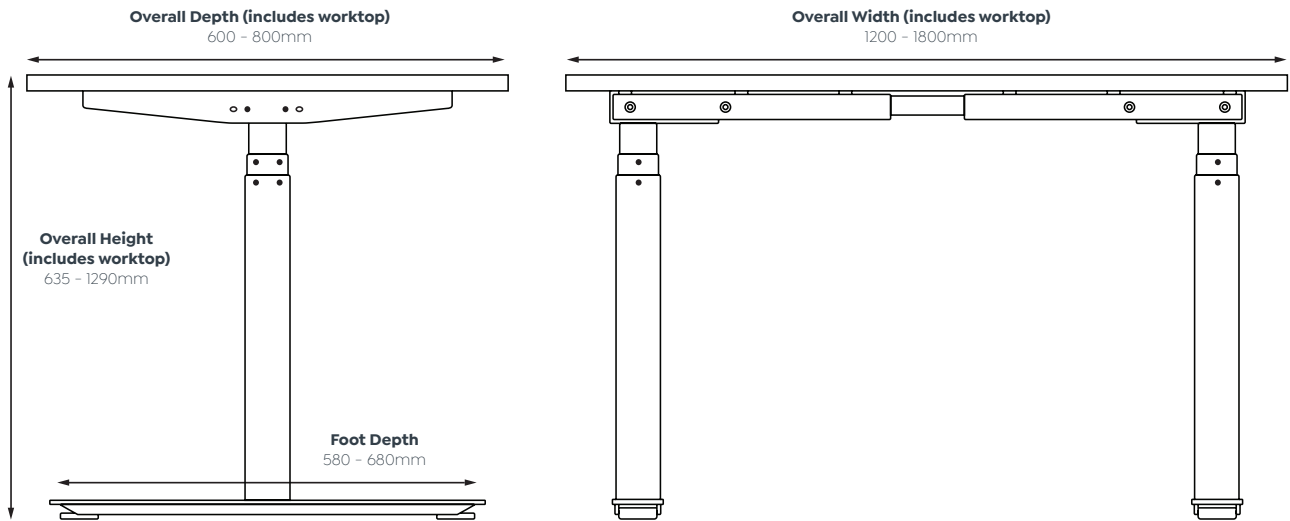

Screen Dimensions

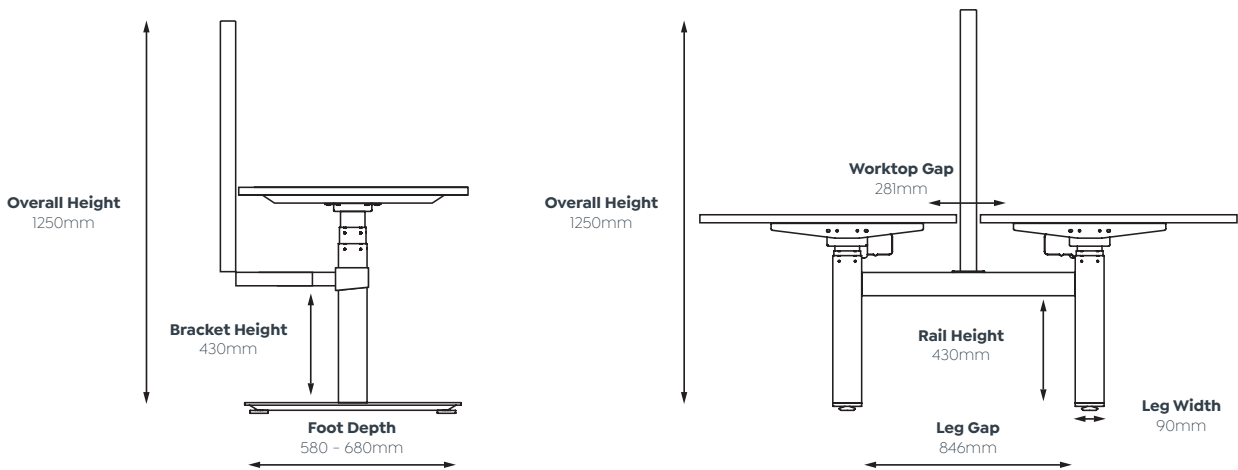

90° & 120° Dimensions

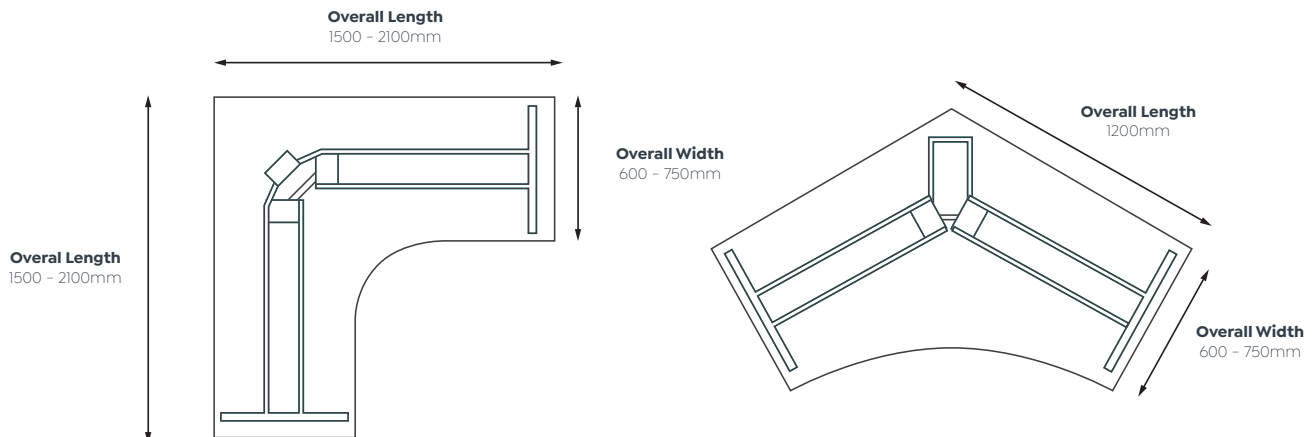

AgileMotion+ Electric Desk.

Workstation Configurations

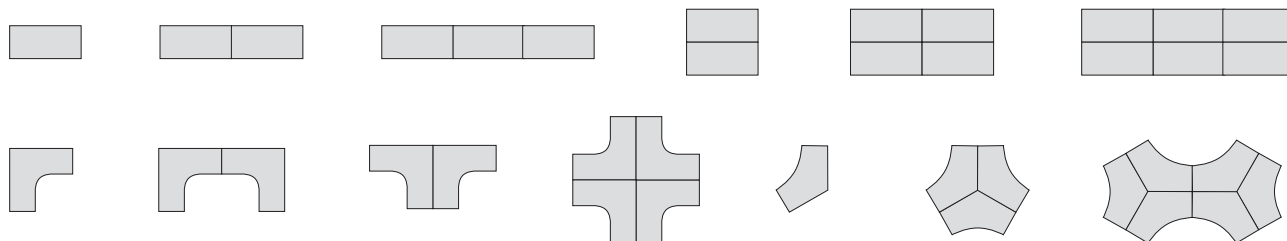

Available Sizes

Single Sided

1200 x 600mm	1200 x 750mm	1200 x 800mm
1500 x 600mm	1500 x 750mm	1500 x 800mm
1600 x 600mm	1600 x 750mm	1600 x 800mm
1800 x 600mm	1800 x 750mm	1800 x 800mm

Double Sided

2 x 1200 x 600mm	2 x 1200 x 750mm	2 x 1200 x 800mm
2 x 1500 x 600mm	2 x 1500 x 750mm	2 x 1500 x 800mm
2 x 1600 x 600mm	2 x 1600 x 750mm	2 x 1600 x 800mm
2 x 1800 x 600mm	2 x 1800 x 750mm	2 x 1800 x 800mm

Single 90°

1800 x 1800 x 600mm
1800 x 1800 x 750mm

Single 120°

1200 x 1200 x 600mm
1200 x 1200 x 750mm

AgileMotion+ Electric Desk.

Cheat Sheet Quick Guide

Standard Features

- 90 x 60 mm legs
- Frames finished in white or black powdercoat
- H frame design - double sided desk
- Concealed motors in each leg
- Commercial-grade 25 mm worktops are constructed from E0 board and finished in white melamine with matching 2 mm
- Electric Double motor height range- 635-1290 mm. Adjustment speed 30 mm/s
- 160 kg weight rating (evenly distributed)
- 4 point memory control with LCD readout, programmable to restrict min/ max height and to set anti-collision sensitivity
- Fast to assemble - rails come pre-fitted to the legs where possible
- 10 year warranty - best in its class

Optional Upgrades

- 50mm Studio screens
- 50mm Studio screens with intergrated cable duct
- 10, 20 & 30mm AcoustiQ screens
- Cable trays - system includes desk to desk bridges, power/ data mounting points (inside the tray or on the vertical face) and cable snakes to the desktop

Upgrade Options

- Double Sided Workstation
- 90° Workstation
- 120° Workstation
- Cable Management Solutions
- Multiple Screen Options Available

Mellamine Worktop Colour Options

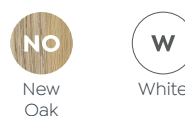

Steel Frame Colour Options



Available in

- Single - Desk
- Single - Workstation
- Shared - Back to Back
- 90° - Workstation
- 120° - Workstation



Breathe

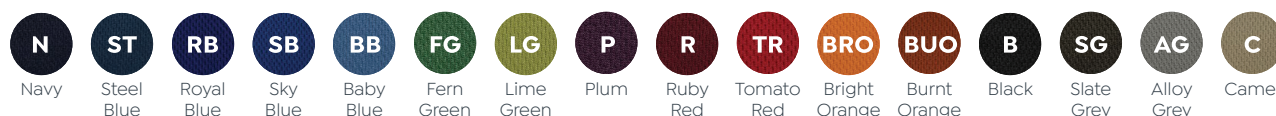

Splice



AcoustiQ Screen Colour Options

