



ASSEMBLY INSTRUCTION

AXIS System Storage Tower-Studio

ITEM No.: AXBST12

OPTION 1 (see page s-6)

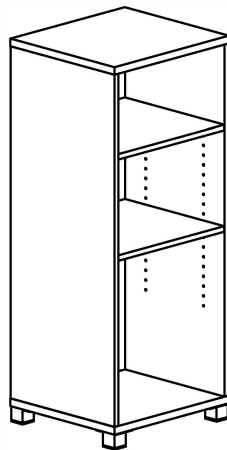

OPTION 2 (see page 7-8)

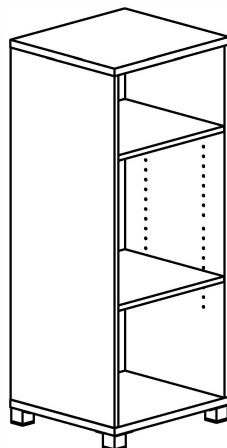

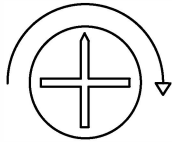

The turning direction of attaching



The arrow direction=front

Incorrect Correct

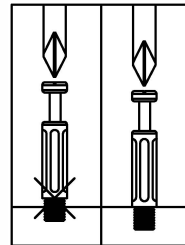

OPTION 1

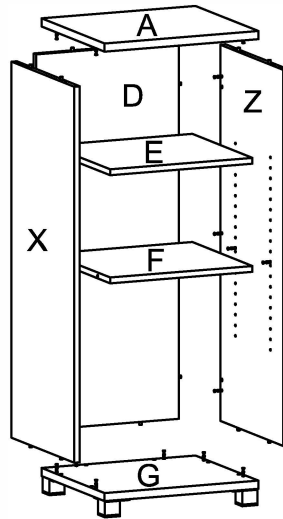

OPTION 2

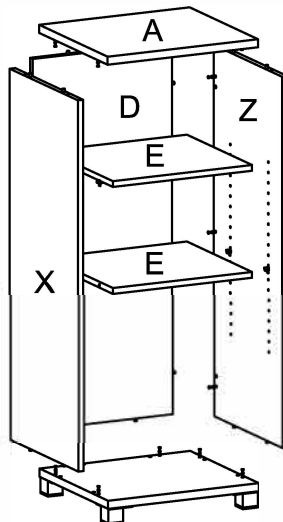

PARTS LIST

ITEM	DESCRIPTION	QTY.	ITEM	DESCRIPTION	QTY.
A	Top panel	1	@	6*35 Cam Bolt	22
X	Left side panel	1	@	8*30 Dowel pin	16
Z	Right side panel	1	@	(%) Cam Cover	22
D	Back panel	1	@	Threaded Dowel Pin	4
G	Bottom panel	1	(R)	4*16 Screw	12
E	Moveable shelf	1	@	Metal Leg	4
F	Immovable panel	1	@	Height Adjuster	4

i

I

i

@ 6*35 Cam Bolt-22

@ 8*30 Dowel Pin-16

@ (1/2") Cam Cover-22

@ 4*16 Screw-12



@ Threaded Dowel Pin-4

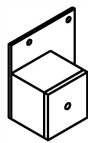

@ Metal Leg-4



@ Height Adjuster- 4

Pre-installed parts

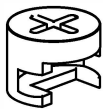

@cam

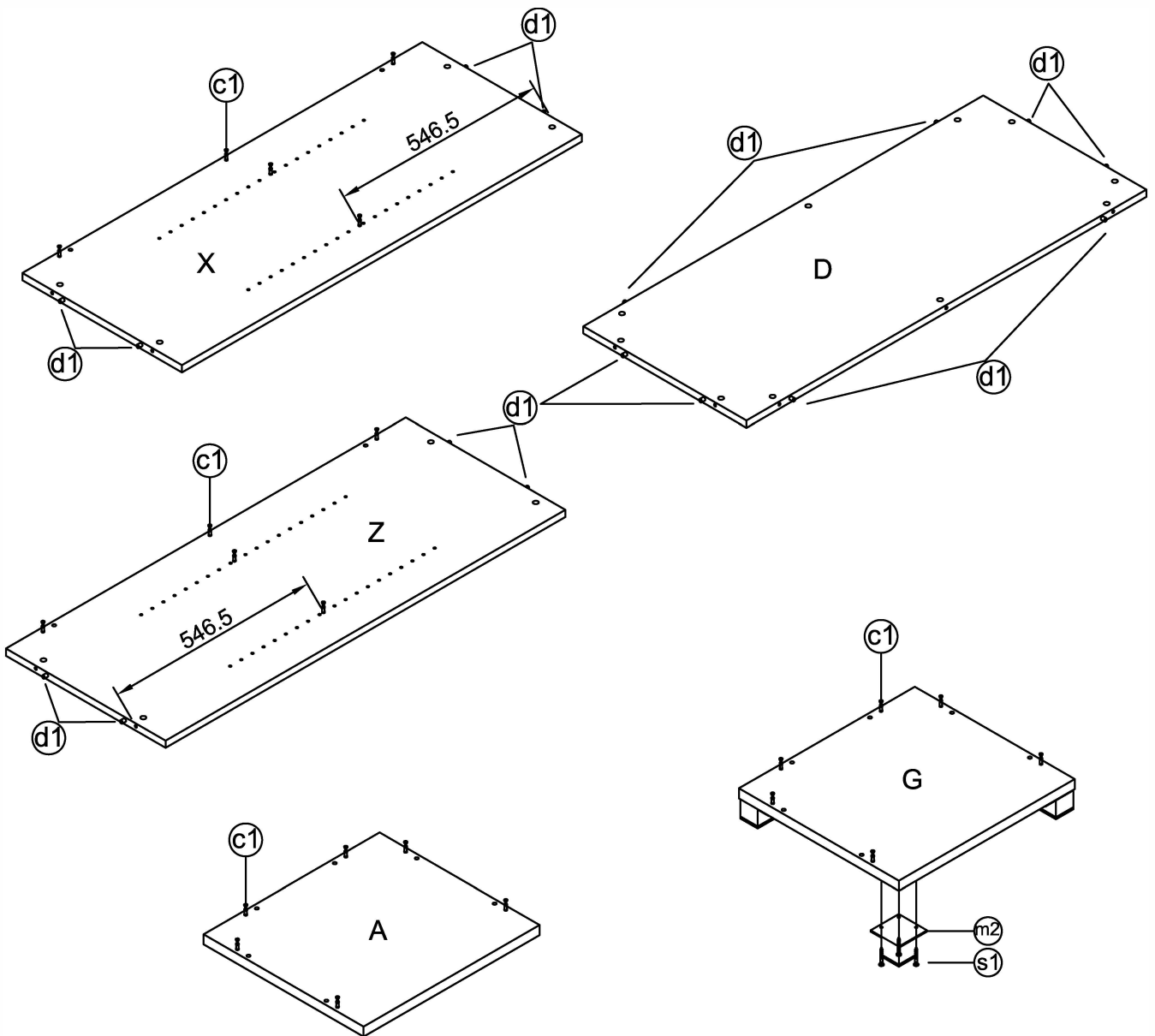

Preparation for Top panel A, Back panel D, Bottom panel G, Left side panel X, Right side panel Z .

- 1, Insert cam bolts@) and dowel pins@ into panels A ,D,G,X and Z as illustrated above.
- 2, Assemble metal legs @ with screws@ on bottom panel G.

OPTION 1

STEP 1

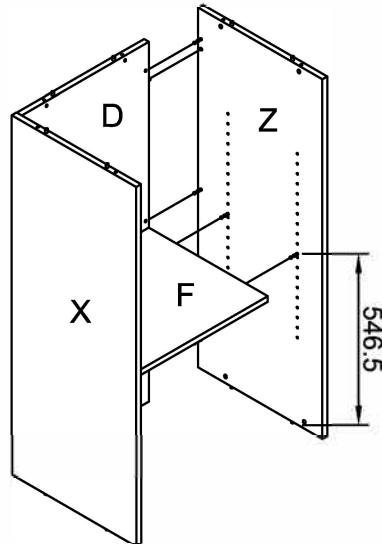

Left side panel X Immovable panel F and Right side panel Z assembly.

- 1.. Insert cam bolts@ and dowel pins@) on panel X F and Z into cams on panel D and tighten in a clockwise direction as illustrated above.

STEP2

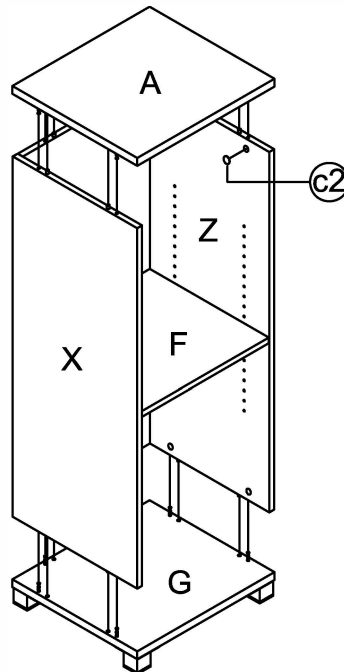

Bottom panel G and Top panel A assembly.

- 1.. Insert cam bolts@) and dowel pins@) on panel G and A into cams on panel X,Z and D and tighten in a clockwise direction as illustrated above.
2. Cover the cam covers@ on the top of cams.

STEP 3

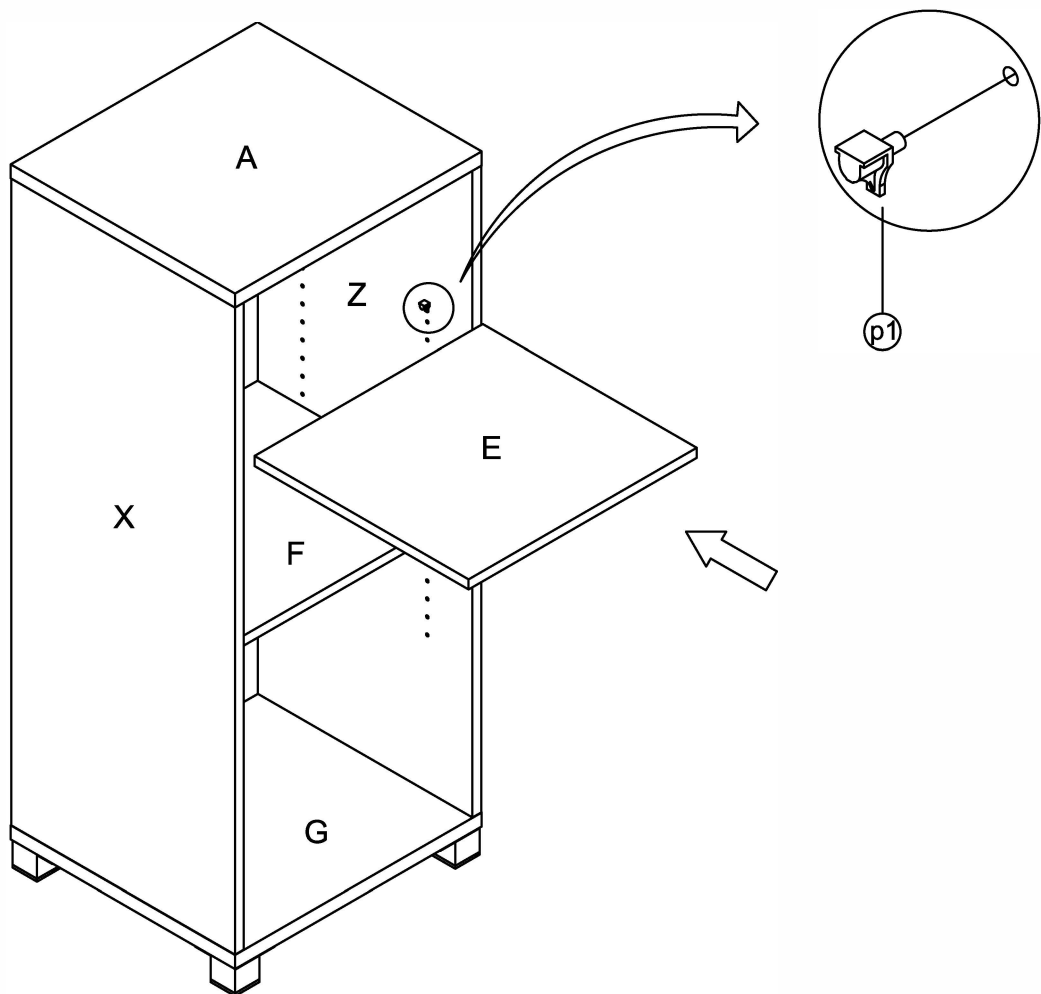

Moveable shelf E assembly.

1. Insert threaded dowel pins @ into panels X, D and Z as illustrated above.
2. Put the two panels E on the top of threaded dowel pins (e) as illustrated above.

OPTION 2

STEP 1

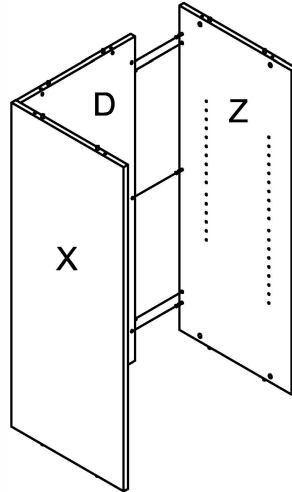

Left side panel X and Right side panel Z assembly.

- 1, Insert cam bolts@ and dowel pins@) on panel X and Z into cams on panel D and tighten in a clockwise direction as illustrated above.

STEP2

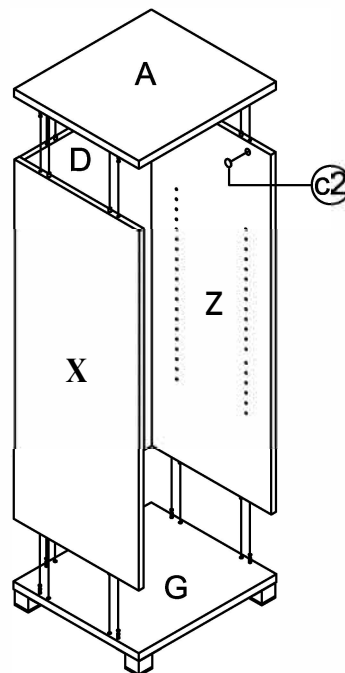

Bottom panel G and Top panel A assembly.

- 1, Insert cam bolts@) and dowel pins d1 on panel G and A into cams on panel X,Z and D and tighten in a clockwise direction as illustrated above.
- 2, Cover the cam covers@ on the top of cams.

STEP 3

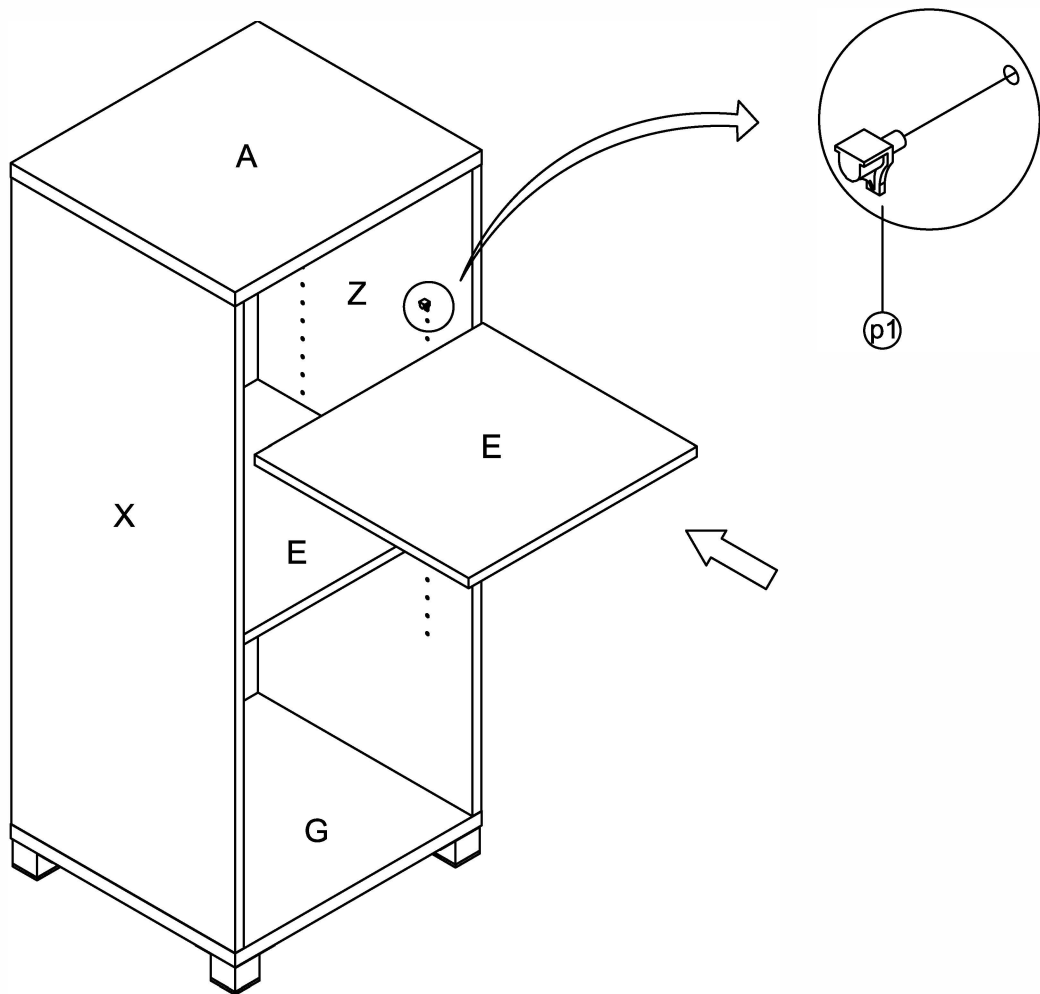

Moveable shelf E assembly.

1. Insert threaded dowel pins @) into panels X, D and Z as illustrated above.
2. Put the two panels E on the top of threaded dowel pins @) as illustrated above.

Remove all QC and panel labels and wipe clean using a damp cloth and general household cleaner.