

# ASSEMBLY INSTRUCTION

AXIS Tambour Cabinet 900H

ITEM No.:AXT9

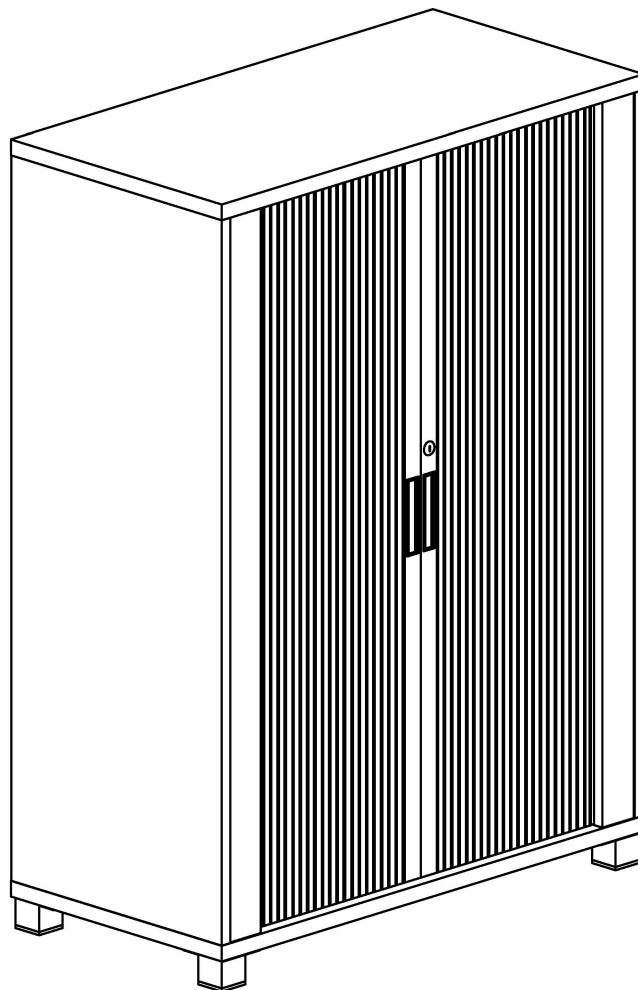

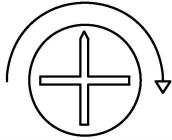

The turning direction of attaching



The arrow direction=front

Incorrect Correct

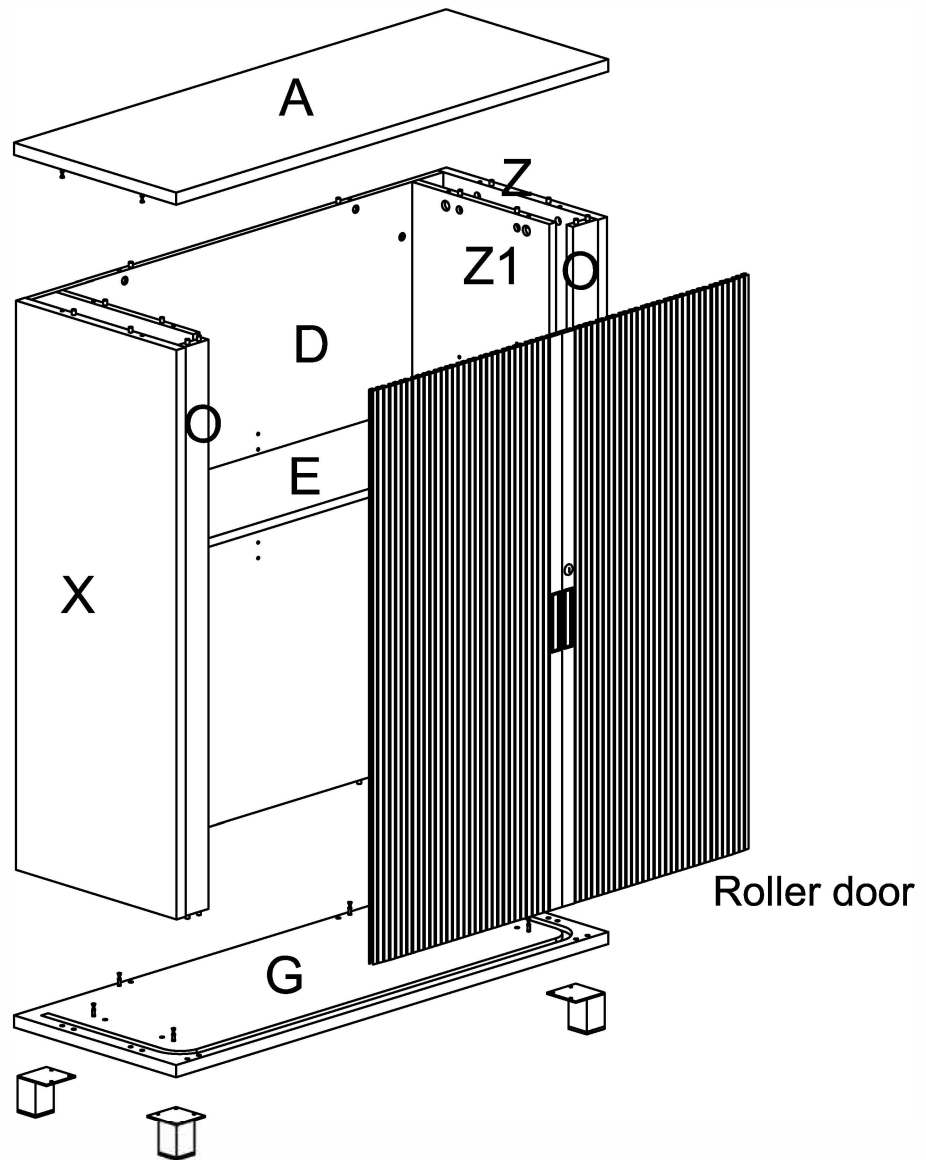
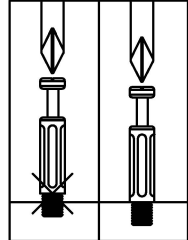

# PARTS LIST

ITEM	DESCRIPTION	QTY.	ITEM	DESCRIPTION	QTY.
A	Top panel	1	(c1)	6*35 Cam Bolt	34
X	Left side panel	1	(d1)	8*30 Dowel pin	36
X1	Left side panel	1	(c2)	(5/8") Cam Cover	38
Z	Right side panel	1	(p1)	Threaded Dowel Pin	5
Z1	Right side panel	1	(s1)	4*16 Screw	12
D	Back panel	1	(m2)	Metal Leg	4
G	Bottom panel	1	(a22)	Height Adjuster	4
E	Moveable shelf	1	(s20)	6*50 Fix Bolt	4
O	Batten	2			



(c1) 6\*35 Cam Bolt-34



(d1) 8\*30 Dowel Pin-36



(c2) (5/8") Cam Cover-38



(s1) 4\*16 Screw-12



(p1) Threaded Dowel Pin-5

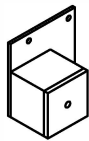

(m2) Metal Leg-4



(a22) Height Adjuster- 4



(s20) 6\*50 Fix Bolt-4

## Pre-installed parts

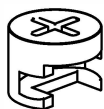

(c5) Cam

# STEP 1

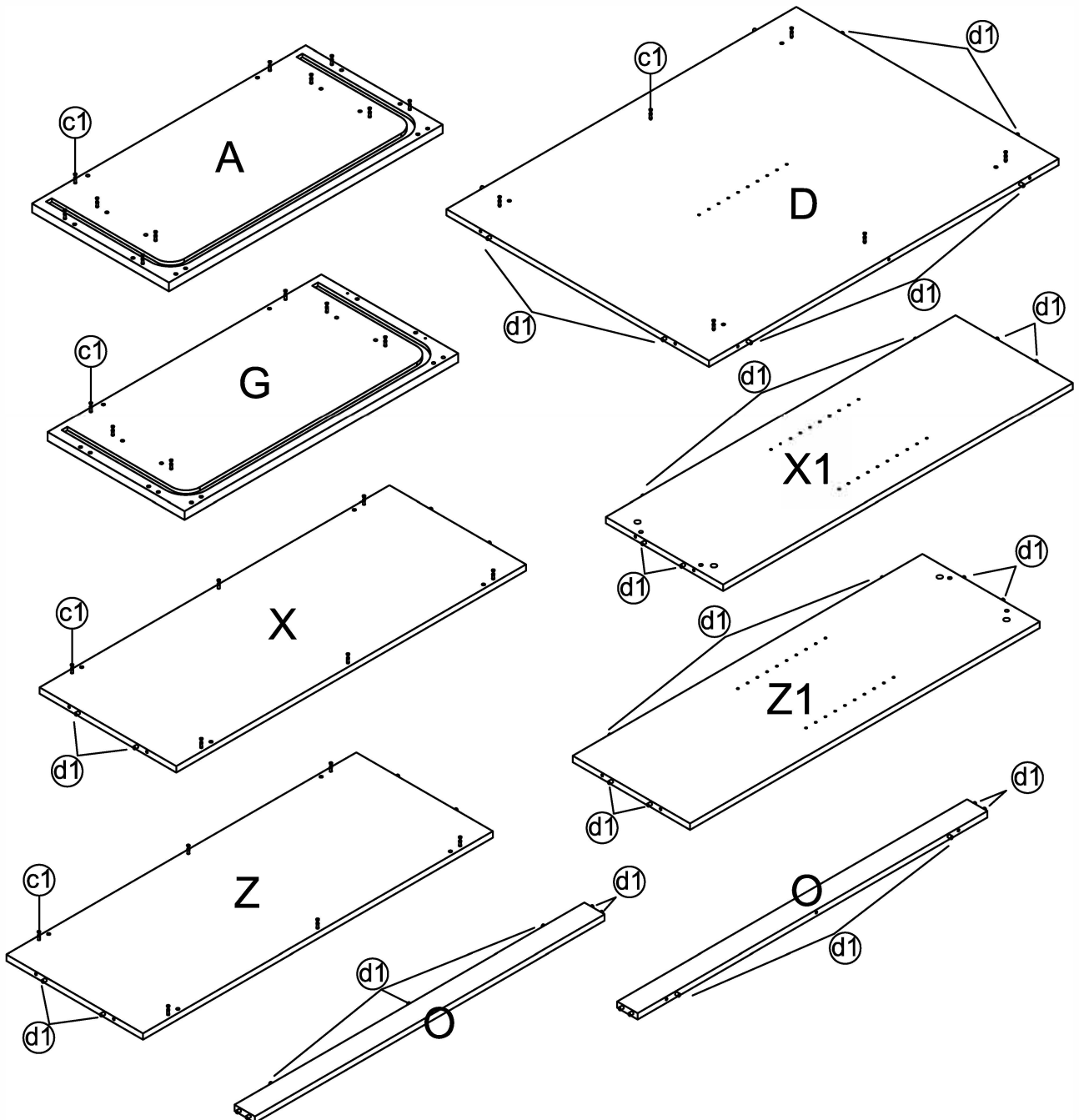

**Preparation for Top panel A, bottom panel G, Vertical batten O, Left side panel X, X1, Right side panel Z, Z1, back panel D .**

- 1、 Insert cam bolts (c1) and dowel pins (d1) into panels A,G,X,X1,Z and Z1 as illustrated above.
- 2、 Insert dowel pins (d1) into panels D,O as illustrated above.

## STEP 2

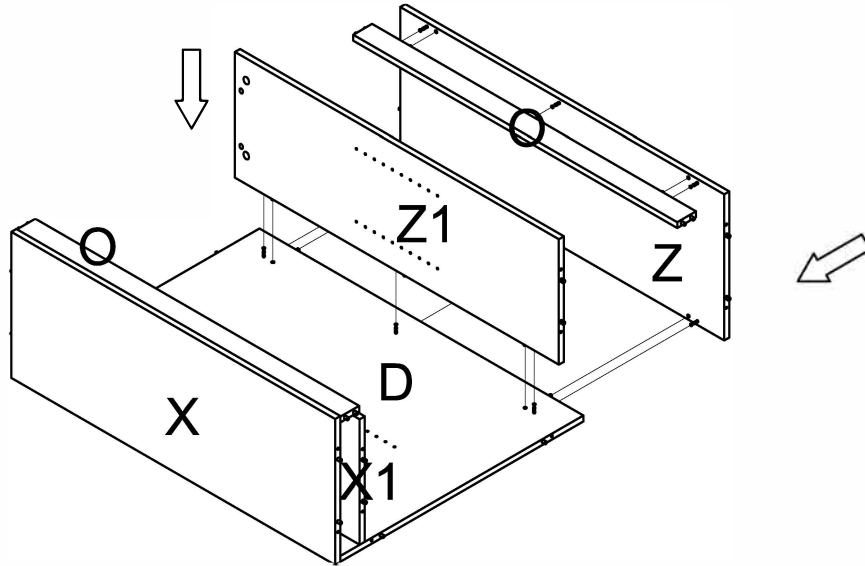

**Back panel D, left side panel X,X1, right side panel Z,Z1 and Batten O assembly.**

- 1、 Insert cam bolts (C1) on panel X,X1 and Z,Z1 into cams on panels D,O and tighten in a clockwise direction as illustrated above.

## STEP 3

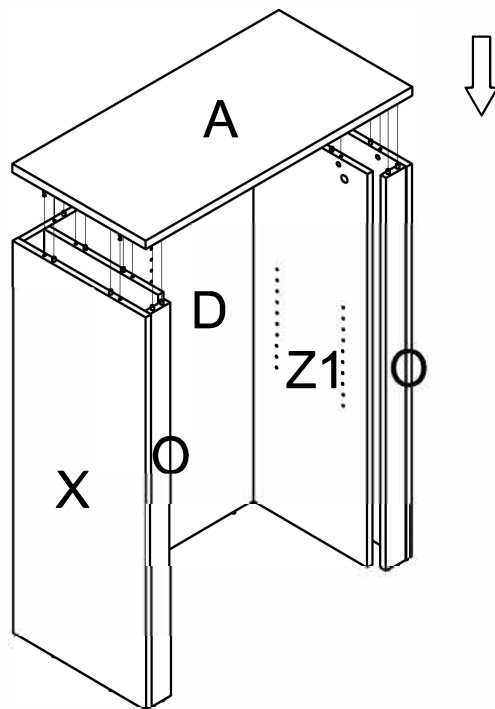

**Top panel A assembly.**

- 1、 Insert cam bolts (C1) on panel A into cams on panels X,X1,Z,Z1,D,O and tighten in a clockwise direction as illustrated above.
- 2、 Tighten the two cams of the panel X depend on the through hole in the panel X1 Z1 as illustrated above.

STEP 4

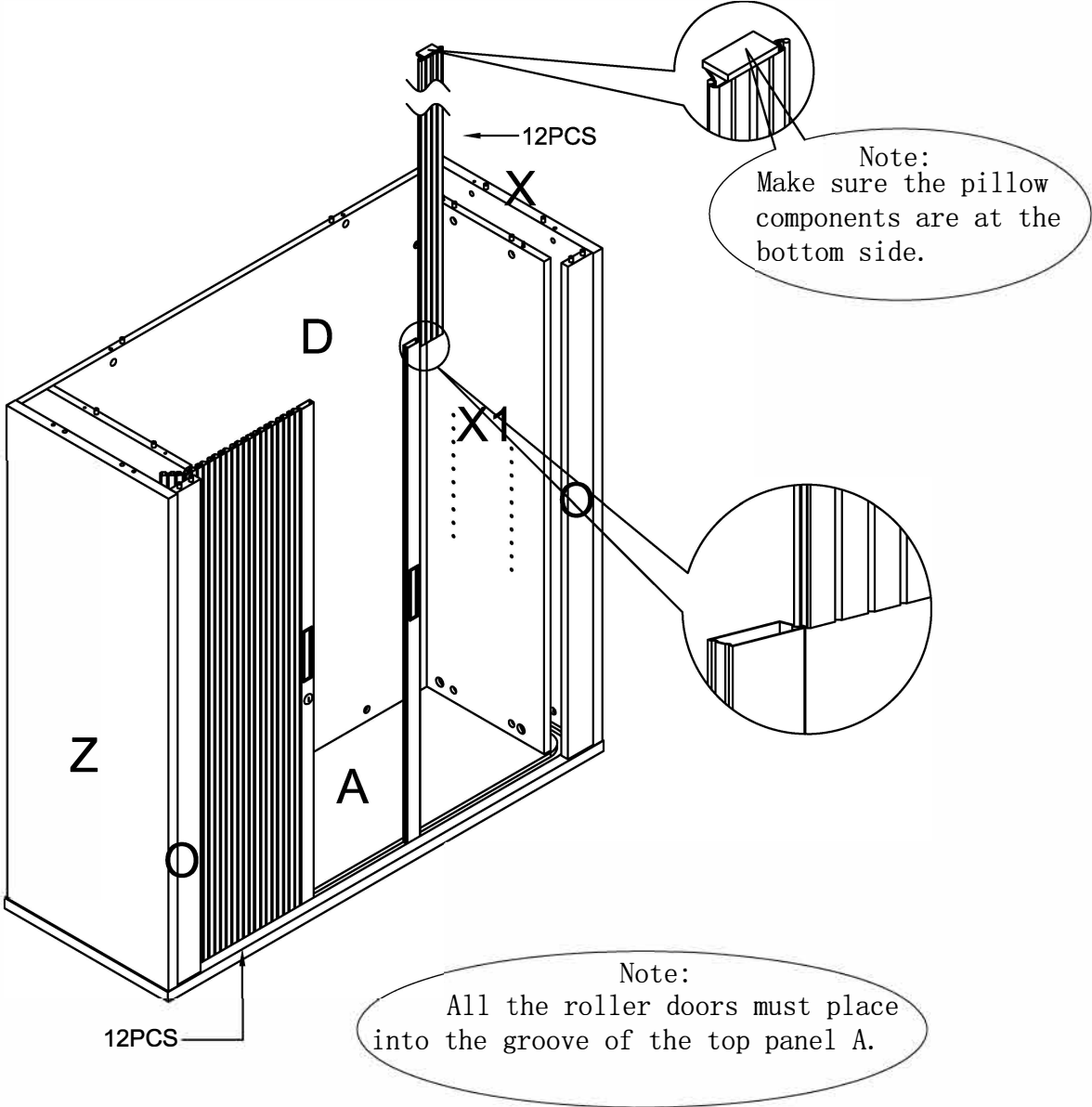

## STEP 5

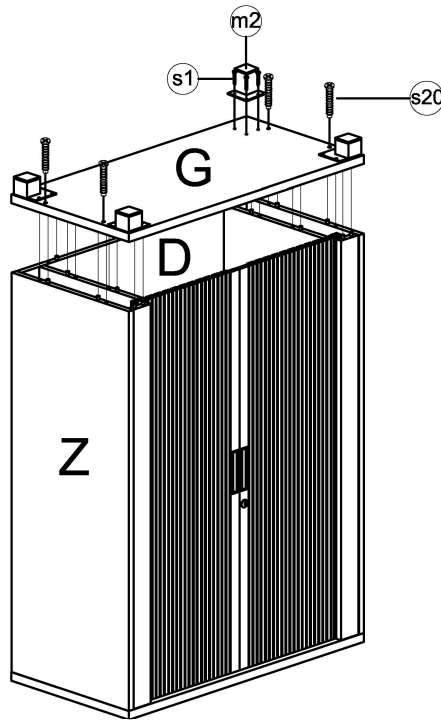

### Bottom panel G assembly.

1. Insert cam bolts (s1) on panel G into cams on panels X,X1,D,Z,Z1,O and tighten in a clockwise direction as illustrated above.
2. Tighten the panel bottom G on the panel X,Z with fix bolt (s20) as illustrated above.
3. Fix Metal Leg (m2) to panels G with screws (s1) as illustrated above.

## STEP 6

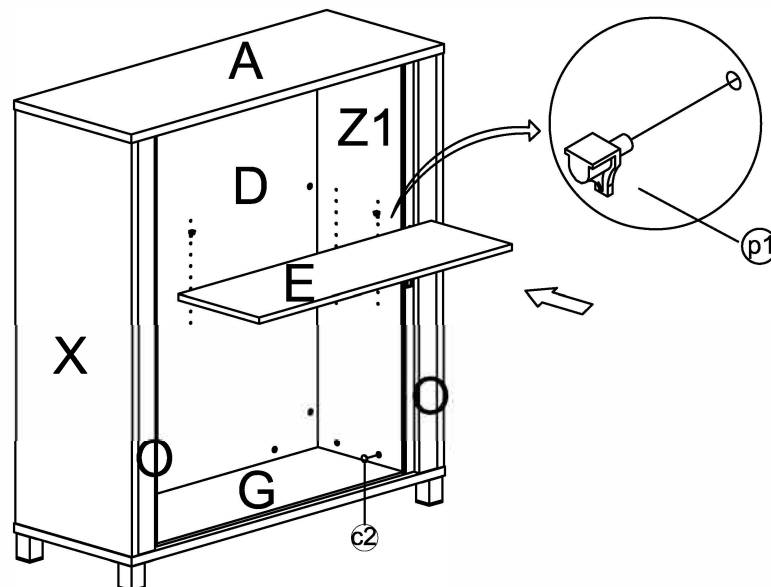

### Moveable shelf E assembly.

1. Insert threaded dowel pins (p1) into panels D,X1 and Z1 as illustrated above.
2. Put the One panels E on the top of threaded dowel pins (p1) as illustrated above.
3. Cover the cam covers (c2) on the top of cams.

---

You have now successfully completed the assembly on item:

**AXIS Tambour Cabinet 900H**

**ITEM No.:AXT9**

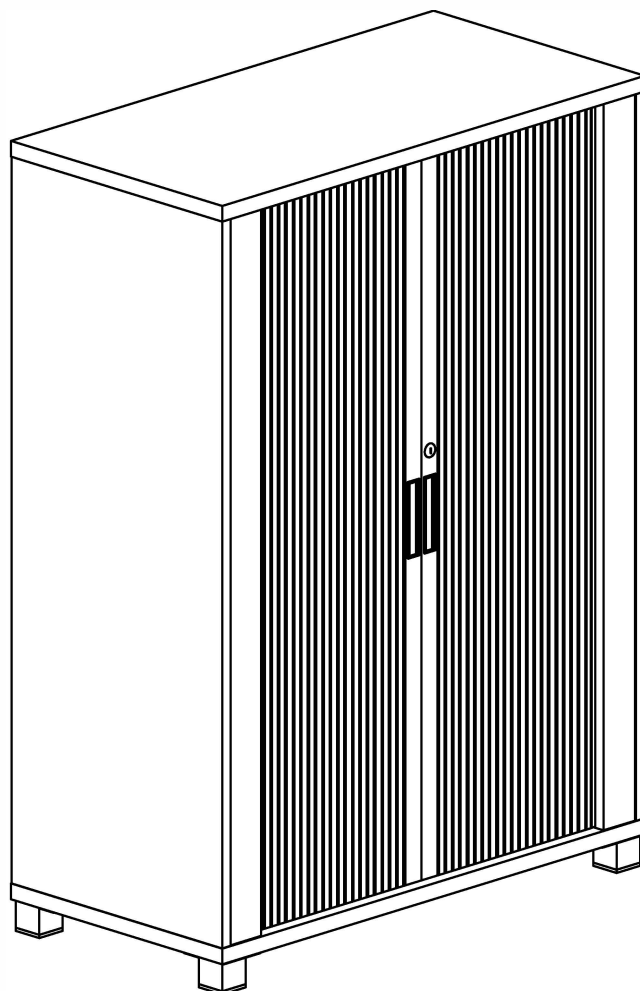

Remove all QC and panel labels and wipe clean using a damp cloth and general household cleaner .