

ASSEMBLY INSTRUCTION

AXIS Credenza 1800W

ITEM No.:AXCZ18

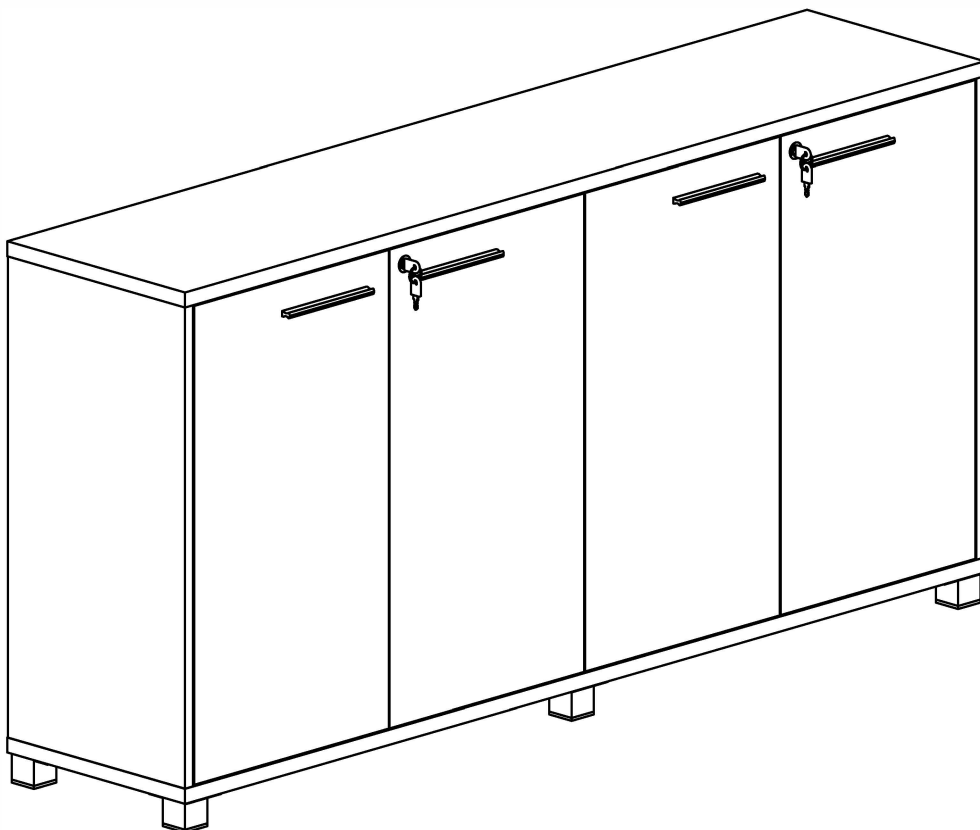

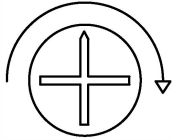

The turning direction of attaching



The arrow direction=front

Incorrect Correct

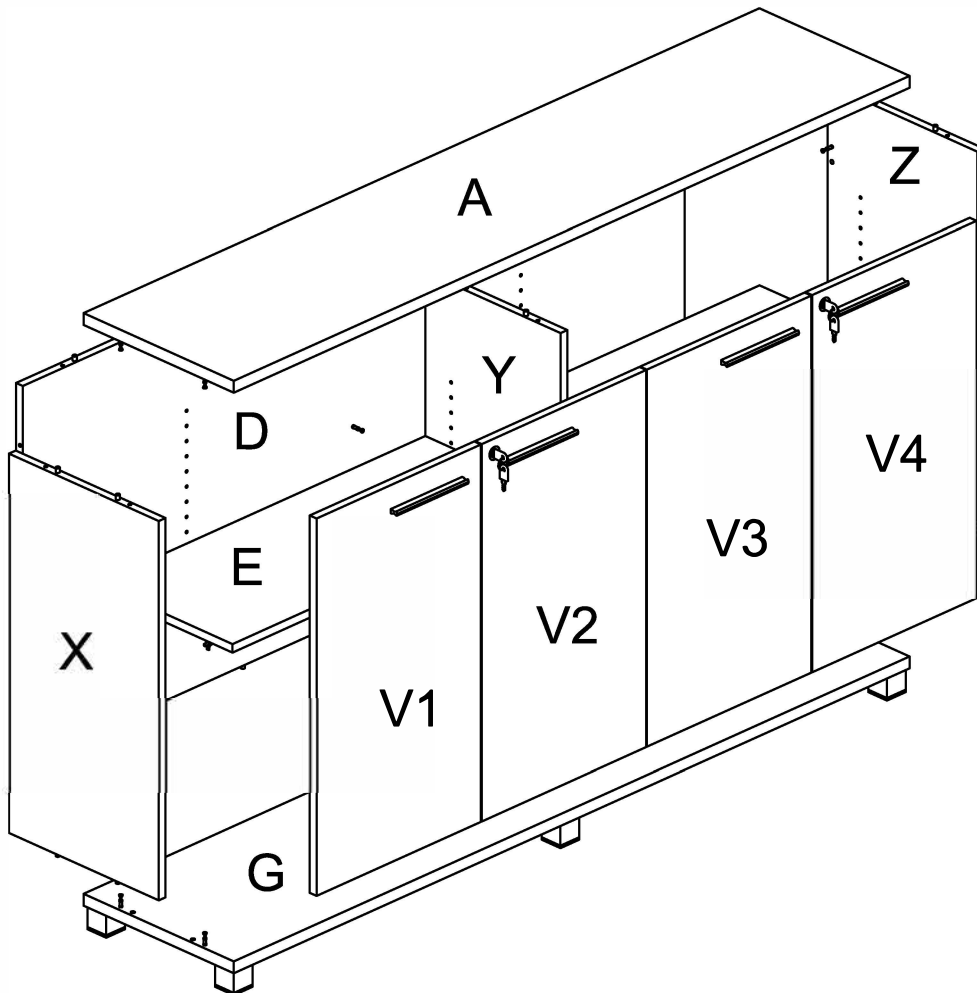
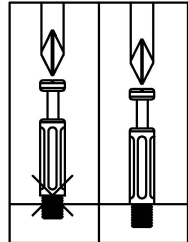

PARTS LIST

ITEM	DESCRIPTION	QTY.	ITEM	DESCRIPTION	QTY.
A	Top panel	1	(c1)	6*35 Cam Bolt	24
X	Left side panel	1	(d1)	8*30 Dowel pin	24
Z	Right side panel	1	(c2)	(5/8") Cam Cover	24
D	Back panel	1	(p1)	Threaded Dowel Pin	10
G	Bottom panel	1	(s1)	4*16 Screw	62
E	Moveable shelf	2	(m2)	Metal Leg	6
Y	Vertical panel	1	(a22)	Height Adjuster	6
V1	Door panel	1	(k1)	Lock Catch	2
V2	Door panel	1	(k4)	Lock	2
V3	Door panel	1	(k5)	Lock Catch	2
V4	Door panel	1	(h4)	Handle	4
			(s7)	4*22 Fix Bolt	8
			(g2)	Big curve Hinge & Mount Plate	4
			(g3)	Small curve Hinge & Mount Plate	4
			(g1)	Hinge Stand	8



c1 6*35 Cam Bolt-24



d1 8*30 Dowel Pin-24



e2 (3/8") Cam Cover-24



f1 4*16 Screw-62



p1 Threaded Dowel Pin-10

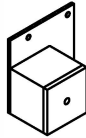

m2 Metal Leg-6



a22 Height Adjuster- 6

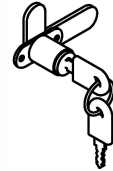

k4 Lock-2

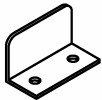

k1 Lock Catch-2



k5 Lock Catch-2



s7 4*22 Fix Bolt-8

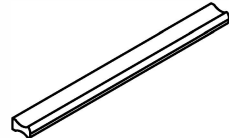

h4 Handle-4



g1 Hinge Stand-8

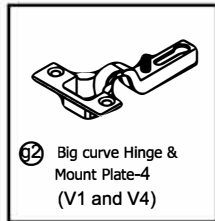

g2 Big curve Hinge & Mount Plate-4 (V1 and V4)

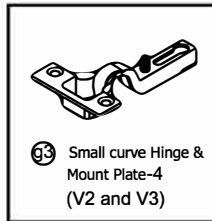

g3 Small curve Hinge & Mount Plate-4 (V2 and V3)

IMPORTANT:

Please note the difference between parts g2 and g3. Each hinge is specifically designed for their unique position. Correct installation is essential for a successful assembly of this credenza.

Pre-installed parts

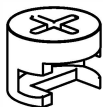

c5 Cam

STEP 1

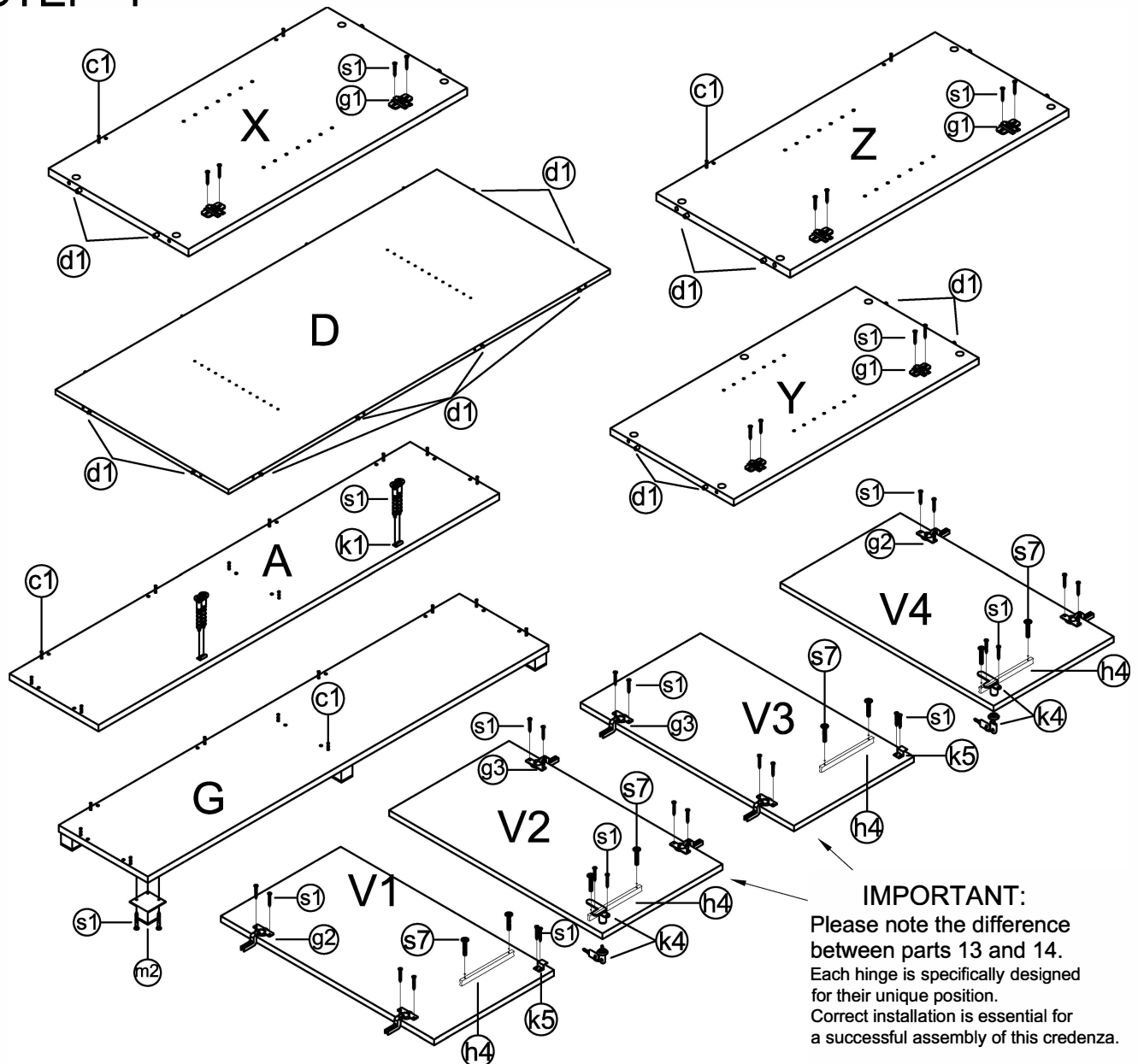

Preparation for Top panel A, Bottom panel G, Left side panel X, Right side panel Z, Vertical panel Y, Door panel V1, V2, V3 and V4 .

- 1、 Insert cams bolts (c1) and dowel pins (d1) into panels A, G, X, and Z as illustrated above.
- 2、 Fix hinge stands (g1) to panels X, Z and Y with screws (s1) as illustrated above.
- 3、 Fix hinge bodies (g2) to panels V1 and V4 with screws (s1) as illustrated above.
- 4、 Fix hinge bodies (g3) to panels V2 and V3 with screws (s1) as illustrated above.
- 5、 Fix handles (h4) to panels V1, V2, V3 and V4 with fix bolts (s7) as illustrated above.
- 6、 Fix metal leg (m2) to panel G with screws (s1) as illustrated above.
- 7、 Fix lock (k4) to panel V2, V4 with screws (s1) as illustrated above.
- 8、 Fix lock catch (k5) to panel V1, V3 with screw (s1) as illustrated above .
- 9、 Fix lock catch (k1) to panel A with screws (s1) as illustrated above.

STEP 2

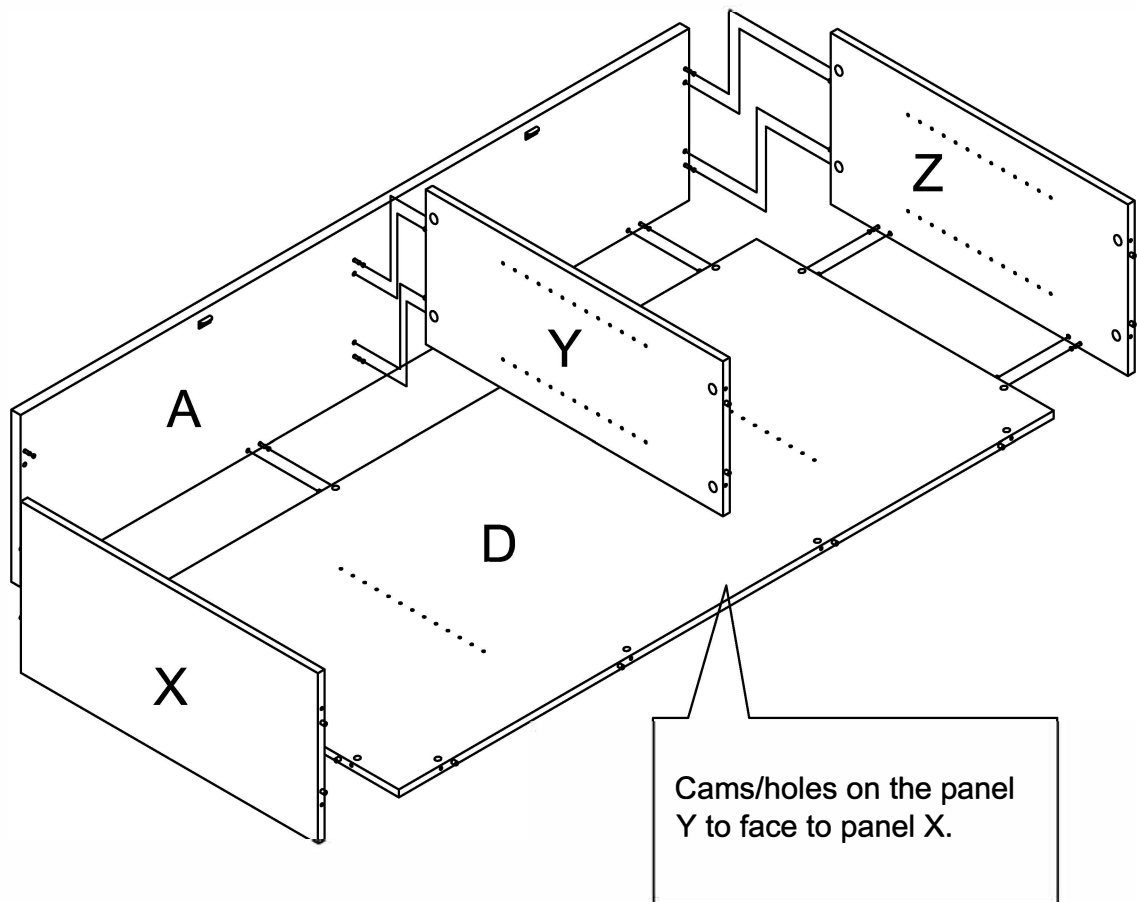

Top panel A, Back panel D, Left side panel X ,Right side panel Z,Vertical panel Y assembly.

- 1、 Fix cams on panel X,Z,Y,D into cam bolts (C1) on panel A and tighten in a clockwise direction as illustrated above.

STEP 3

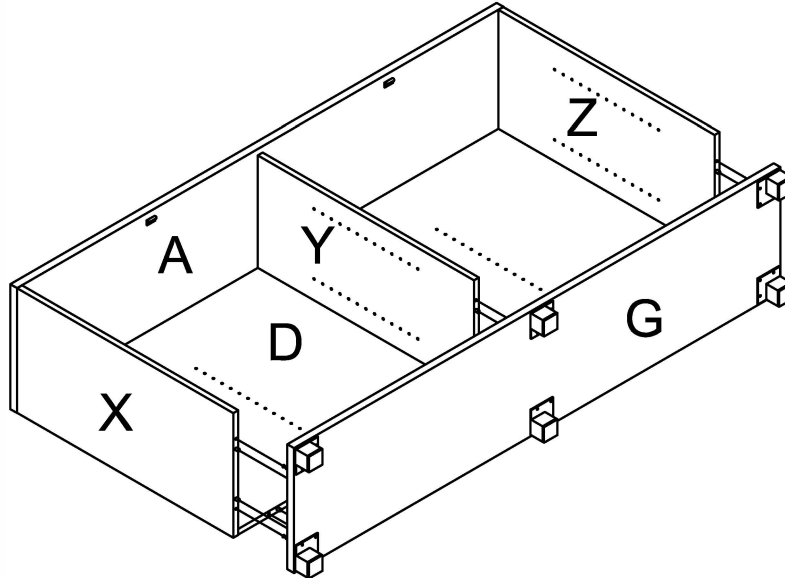

Bottom panel G assembly.

1. Fix cams on panel X, Y, Z and D into cam bolts (C1) on panel G and tighten in a clockwise direction as illustrated above.
3. Cover the cam covers (C2) on the top of all the cams.

STEP 4

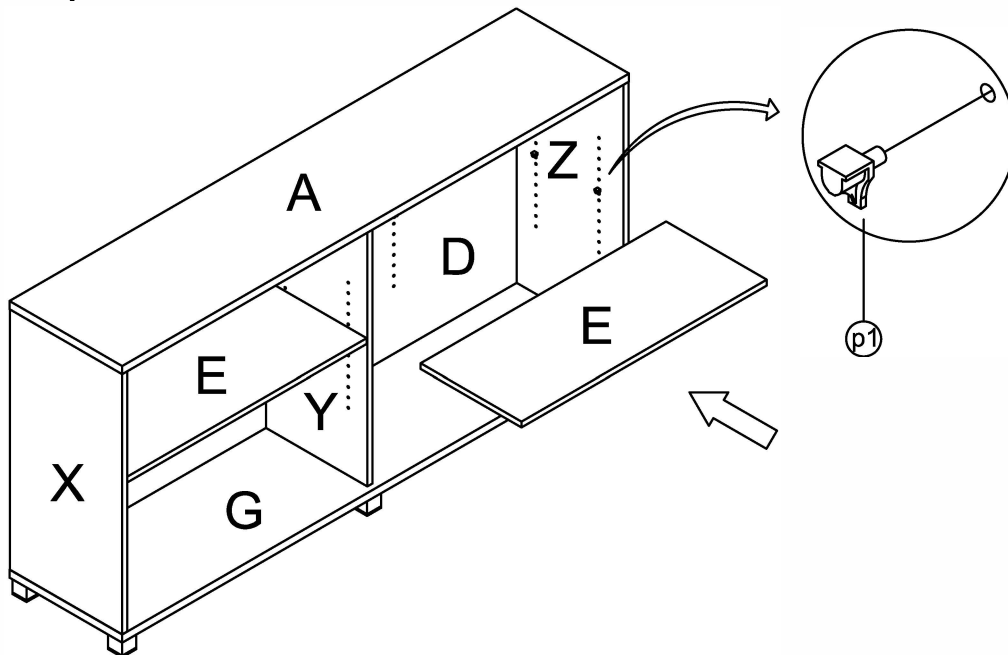

Moveable shelf E assembly.

1. Insert threaded dowel pins (P1) into panels X, Y, Z and D as illustrated above.
2. Put the two panels E on the top of threaded dowel pins (P1) as illustrated above.

STEP 5

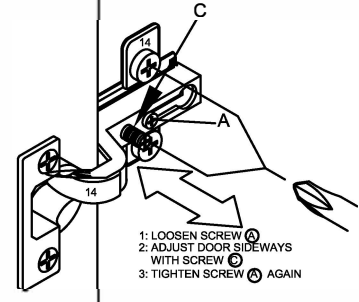
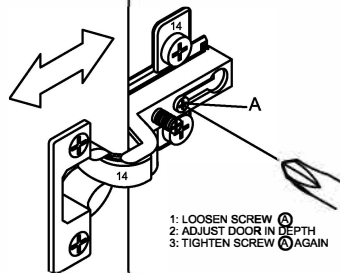
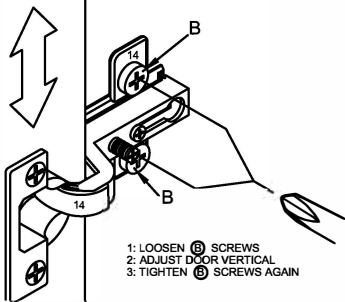
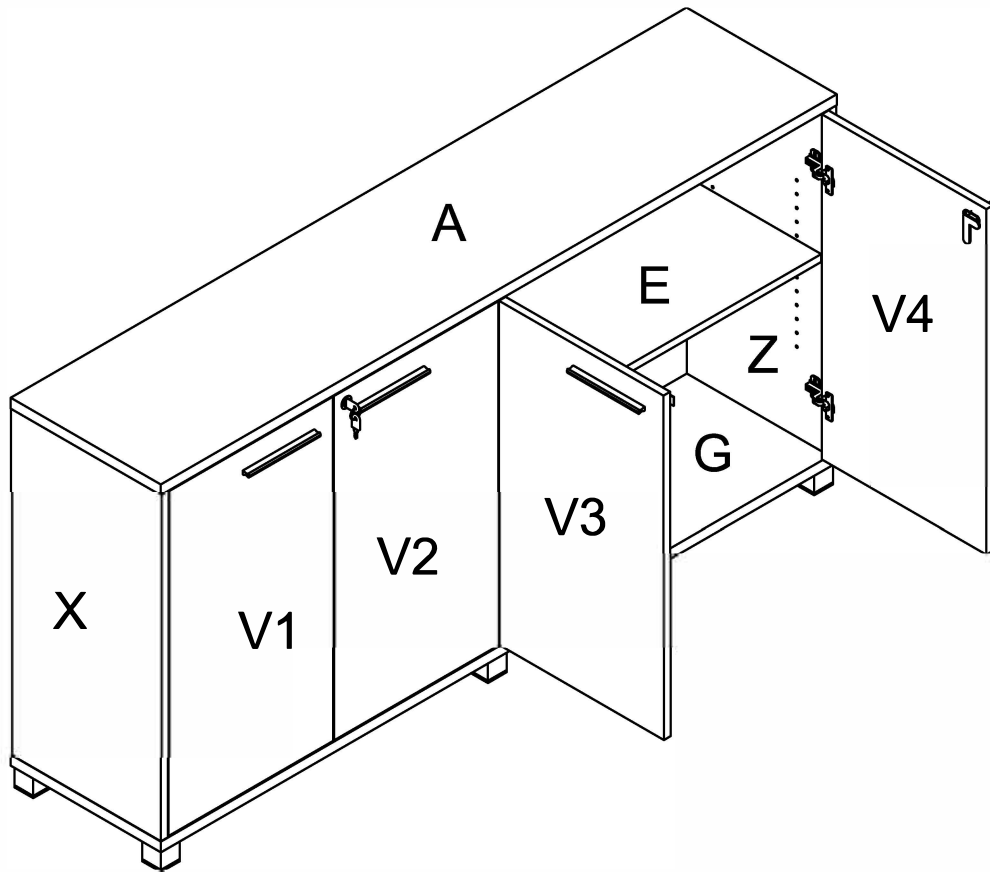

Door panel V1,V2,V3,V4 assembly.

You have now successfully completed the assembly on item:

AXIS Credenza 1800W

ITEM No.:AXCZ18

