



Balance Project

Assembly Instructions

Balance Project

Components List

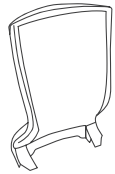

Back Frame

A

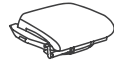

Seat Pan

B



Gas Cylinder

C



Base

D



5 x Caster

E



Hex Wrench

F

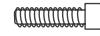

4 x Short Bolt

G

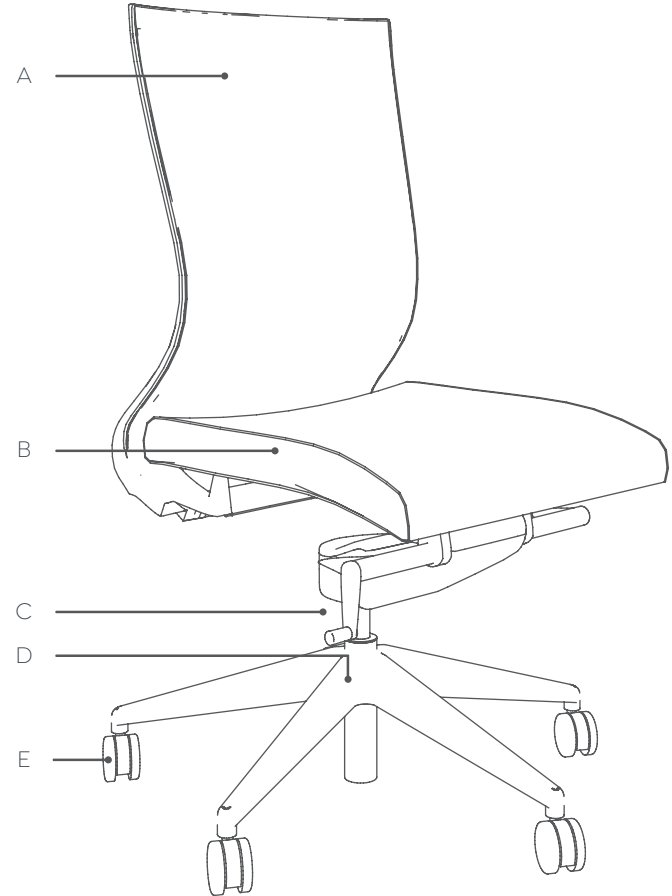

STEP 1:

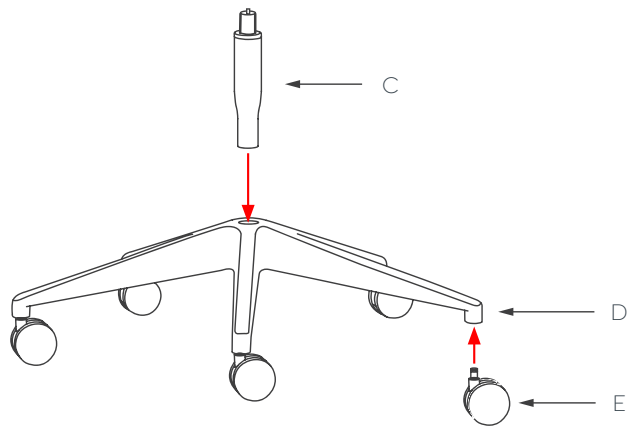

STEP 2:

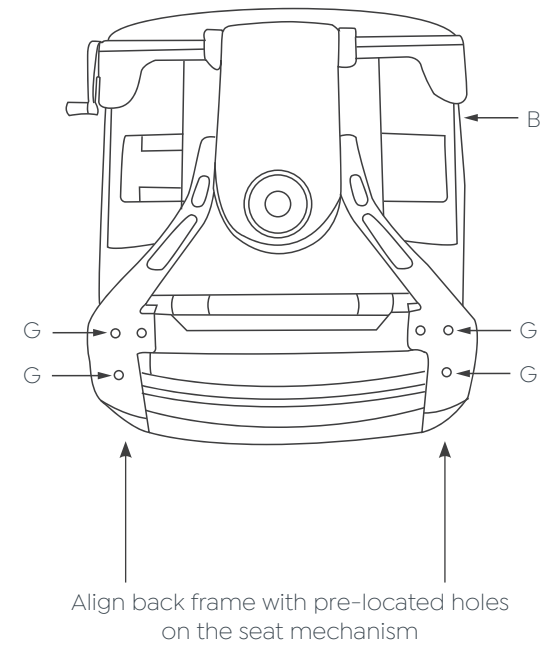

Balance Project

Assembly Instructions

STEP 3:

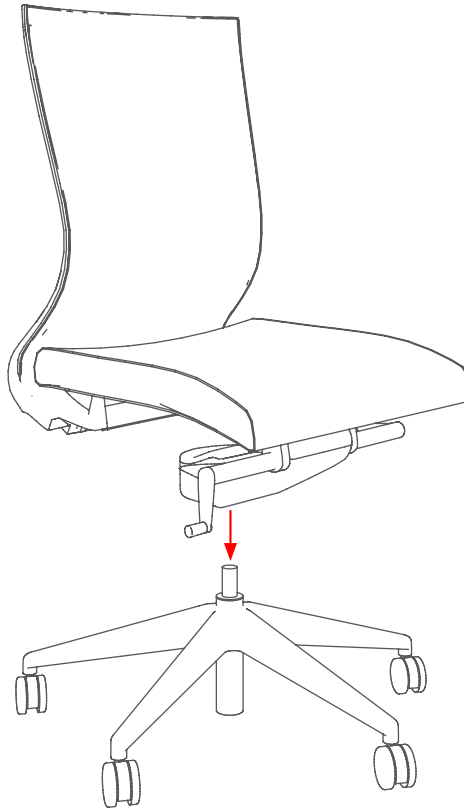

Slip Cover (sold separately)



1. Assemble chair

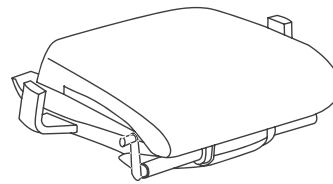

2. Remove old slip cover and foam from seatpan by unfastening the velcro fasteners on the back and front of seat. Remove the back fasteners first.

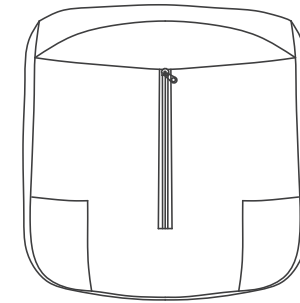

3. Unzip old slip cover and remove from foam.

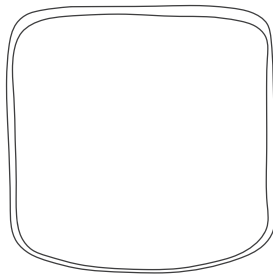

5. Install new slip cover onto the foam.

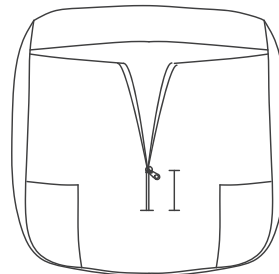

5. Make sure all four slip cover corners match to the foam corners, top & bottom. Close zipper approximately 2"

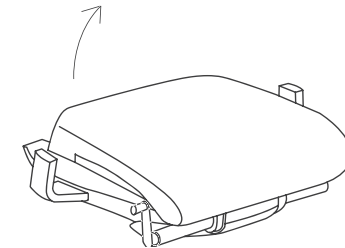

6. Align 2 front corners and install using velcro fasteners. Lift back of seat and zip up slip cover. Align 2 back corners and install using velcro fasteners.