

AgileMotion Electric Desk.

Product **Specifications**



AgileMotion Electric Desk.

AgileMotion is a fully optioned electric height programmable desking system, designed for modern, premium office spaces. The system also integrates seamlessly with the single workstations and back to back desks, and can be further enhanced with fabric privacy panels, floor mounted Studio50 or AcoustiQ screens, monitor arms and personal storage units.

Available in single sided, double sided, 90° and 120° designs, the AgileMotion electric desking system can be fitted with a variety of cable management options and multiple accessories...

Key Features

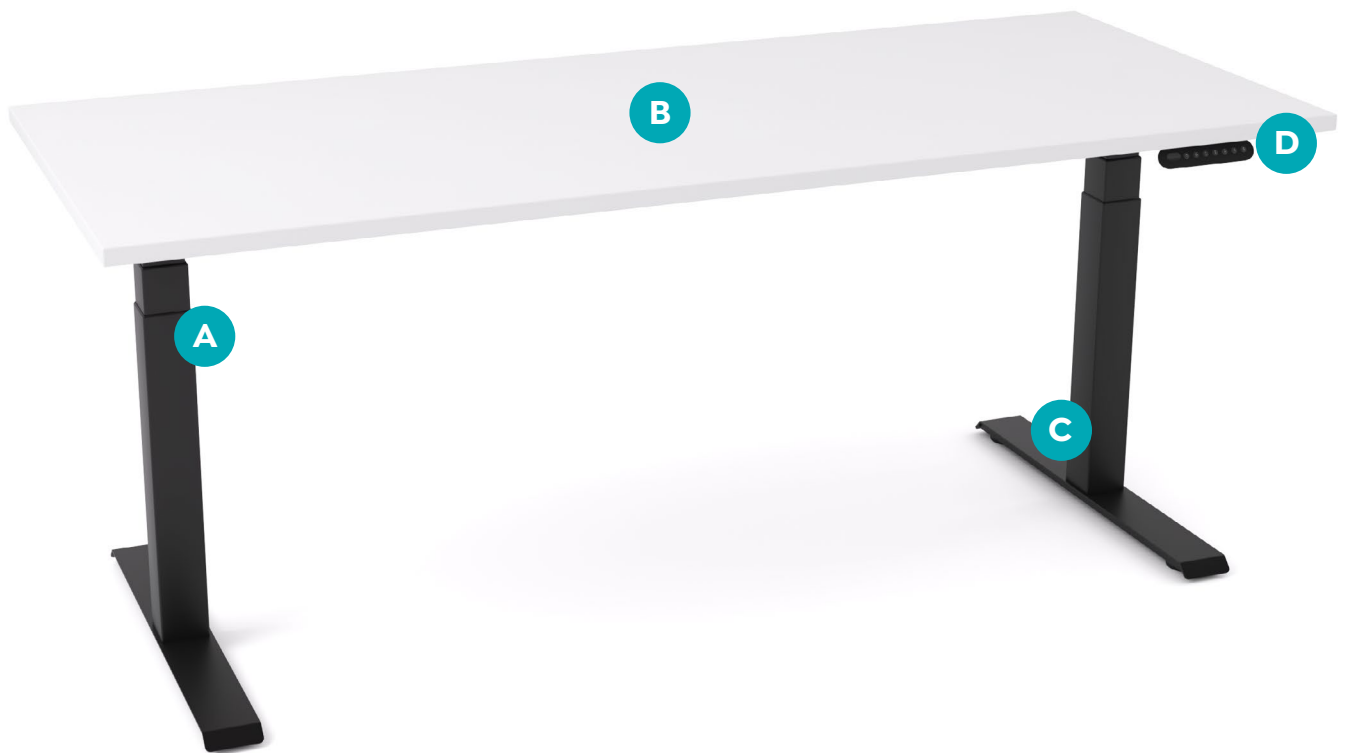

A. Height Adjustment

3 x Column height adjustment from sitting height - 620mm to full standing height - 1270mm.

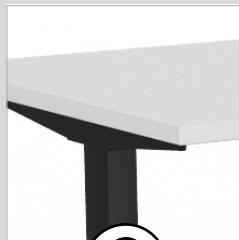

B. E0 Grade Worktop

Commercial grade 25mm melamine worktop constructed with zero formaldehyde.



C. Strong & Durable

Frame is constructed from 2mm Steel for extra strength and stability.

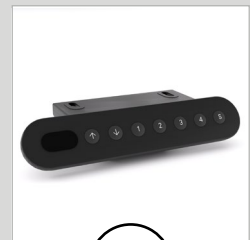

D. Electronic Handset

LED display handset with 4 x programmable memory presets.



AgileMotion Electric Desk.

In Detail



Fast Assembly

Fast to assemble - rails come pre-fitted to the legs where possible.



Anti-Collision

Protect your office equipment against damage with the built-in anti-collision software.



Quiet Motor Operation

Motors are concealed in each leg resulting in whisper quiet operation.



Strong Mechanism

Electric double motor and premium materials results in a weight rating of 140kg when distributed evenly.



Precision Memory

4 point memory control, programmable to restrict min/max height and also to set anti-collision sensitivity.



* Refer to page 8 for Ratings & Certifications details.

AgileMotion Electric Desk.

Optional Upgrades



AgileMotion Single Sided Desk
Black Frame with New Oak Worktop
White frame also available



AgileMotion Double Sided Desk
Black Frame with New Oak Worktop
White fFrame & Worktop also available



AgileMotion Single Sided Desk White Frame
& Worktop with Cable Management
Tray and Studio50 Hung Screen
AcustiQ Screens also available



AgileMotion 90° Single Sided Desk
White Frame with New Oak Worktop
Black frame also available



AgileMotion 120° Single Sided Desk
Black Frame with New Oak Worktop
White frame also available

Mellamine Worktop Colour Options



New Oak



White

Steel Frame Colour Options



Black



White



Studio50
Screens are
Australian
Made.

Breathe



Splice



AcustiQ Screen Colour Options



AgileMotion Electric Desk.

Dimension Specifications

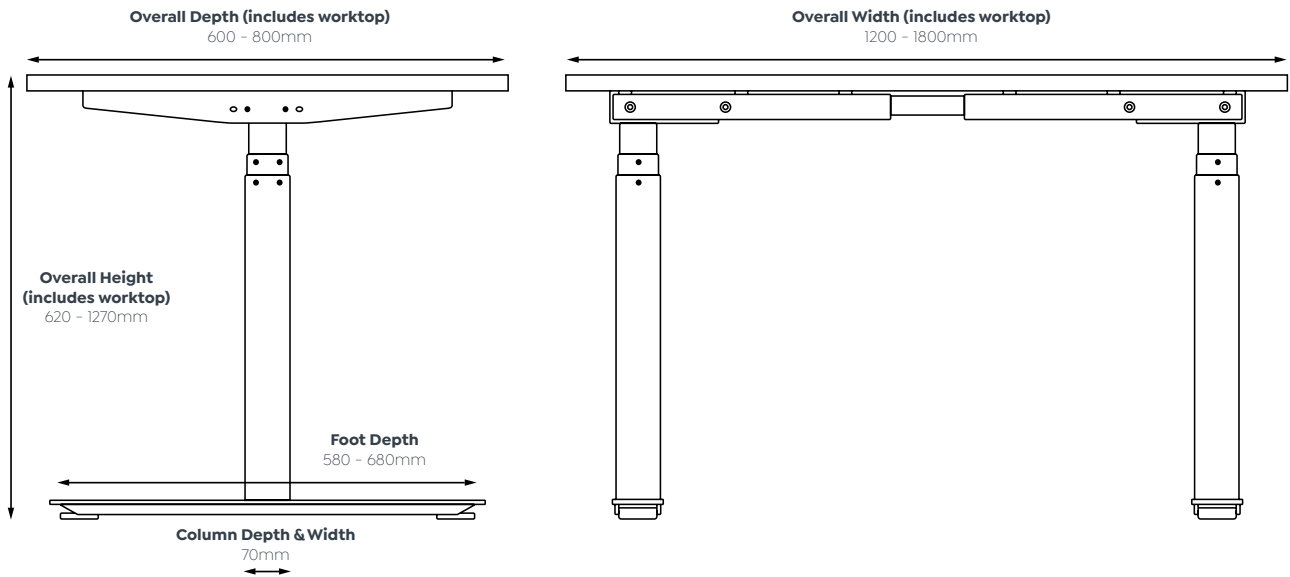

Screen Dimensions

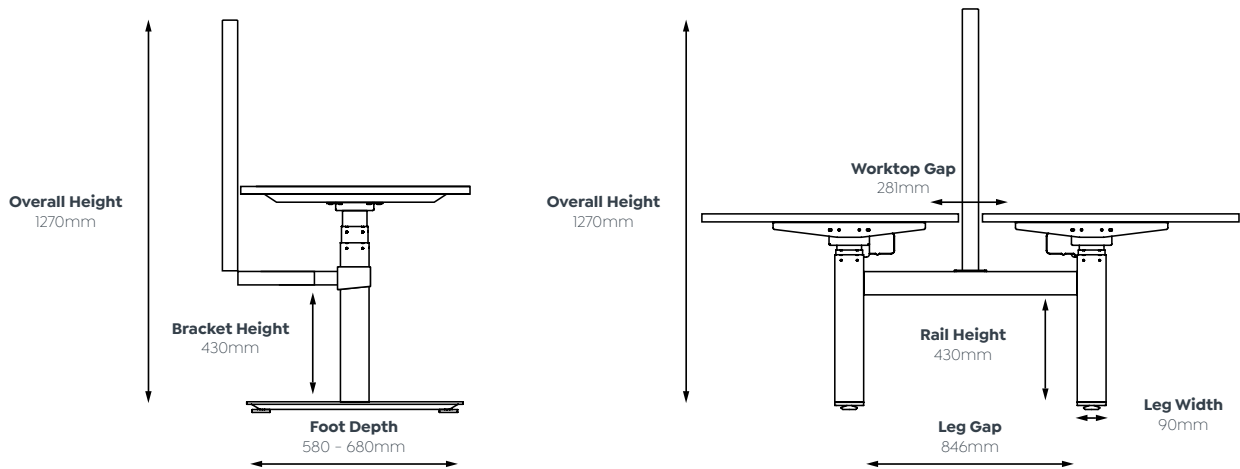

90° & 120° Dimensions

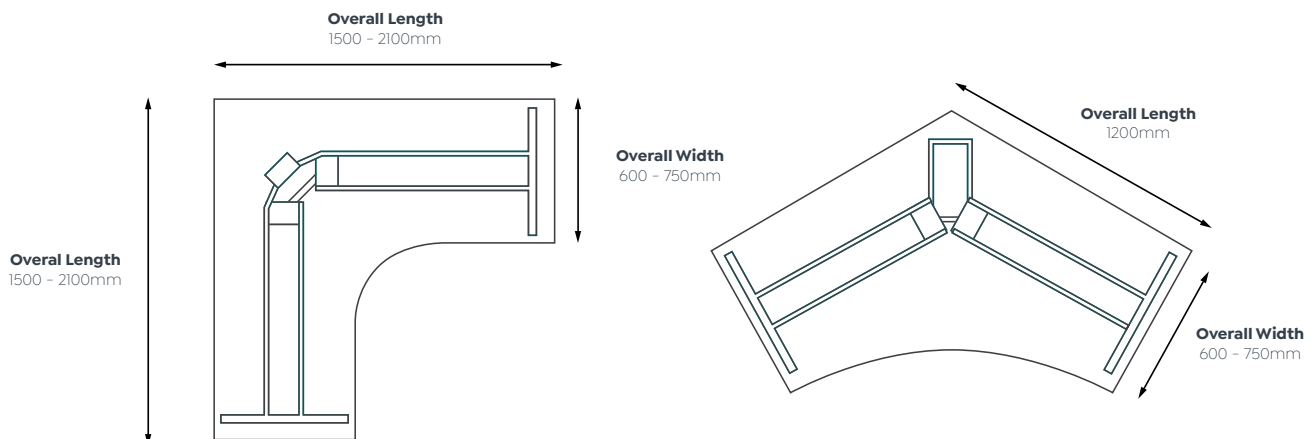

AgileMotion Electric Desk.

Workstation Configurations

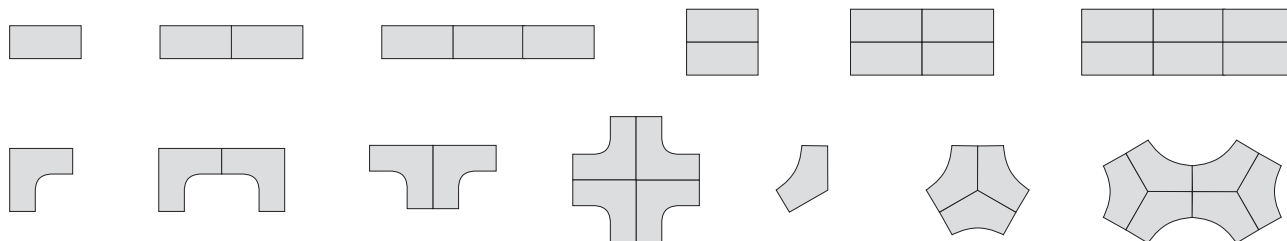

Available Sizes

Single Sided

1200 x 600mm	1200 x 750mm	1500 x 800mm
1500 x 600mm	1500 x 750mm	1800 x 800mm
1600 x 600mm	1600 x 750mm	
1800 x 600mm	1800 x 750mm	

Double Sided

2 x 1200 x 600mm	2 x 1200 x 750mm	2 x 1500 x 800mm
2 x 1500 x 600mm	2 x 1500 x 750mm	2 x 1800 x 800mm
2 x 1600 x 600mm	2 x 1600 x 750mm	
2 x 1800 x 600mm	2 x 1800 x 750mm	

Single 90°

1800 x 1800 x 600mm
1800 x 1800 x 750mm

Single 120°

1200 x 1200 x 600mm
1200 x 1200 x 750mm

AgileMotion Electric Desk.

Cheat Sheet Quick Guide

Standard Features

70 x 70mm legs

Frames finished in white or black powdercoat

H frame design - double sided desk

Concealed motors in each leg

Commercial-grade 25 mm worktops are constructed from E0 board and finished in white melamine with matching 2 mm

Electric Double motor height range- 620-1270mm. Adjustment speed 30 mm/s

140 kg weight rating (evenly distributed)

4 point memory control with LCD readout, programmable to restrict min/max height and to set anti-collision sensitivity.

Fast to assemble - rails come pre-fitted to the legs where possible

10 year warranty - best in its class

Optional Upgrades

50mm Studio screens

50mm Studio screens with integrated cable duct

10, 20 & 30mm AcoustiQ screens

Cable trays - system includes desk to desk bridges, power/data mounting points (inside the tray or on the vertical face) and cable snakes to the desktop

Available in

Single - Desk

Single - Workstation

Shared - Back to Back

90° - Workstation

120° - Workstation



Studio50
Screens are re
Australia n
Made.

Upgrade Options

- Double Sided Workstation
- 90° Workstation
- 120° Workstation
- Cable Management Solutions
- Multiple Screen Options Available

Mellamine Worktop Colour Options



Steel Frame Colour Options



Breathe

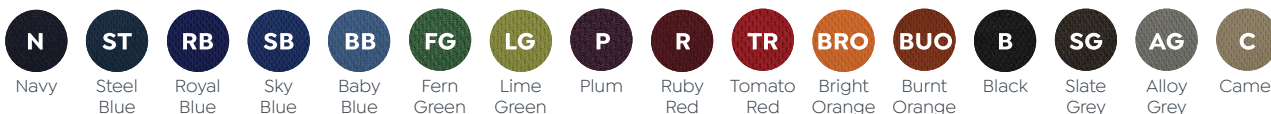

Splice



AcoustiQ Screen Colour Options





AgileMotion double sided desking with Engage seating, Profi x monitor arms and Acoustiq screens.