

---

## **Rover Range (50-ROMC-0913)**

Assembly Instructions

# Rover Range (50-ROMC-0913)

## Components List

ITEM	DESCRIPTION	QTY
A	Top Panel	1
X	Left Side Panel	1
Z	Right Side Panel	1
D	Back Panel	1
E	Moveable Shelf	2
F	Immovable Panel	1
G	Bottom	1

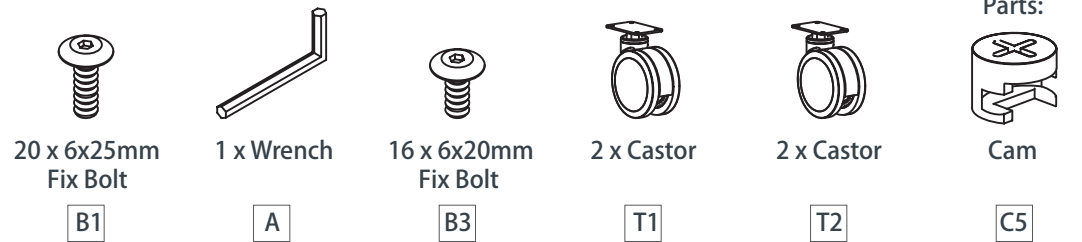
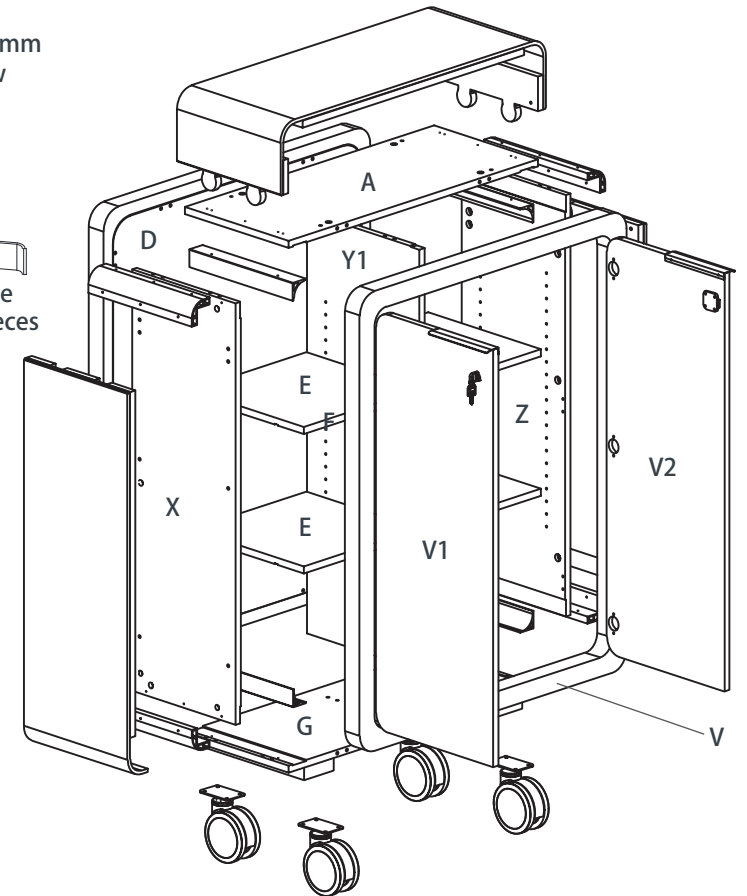
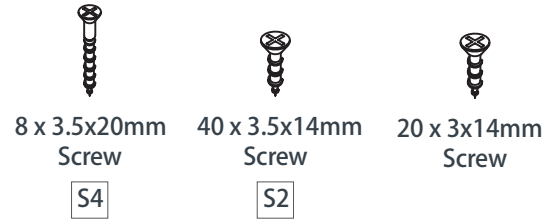

### STEP 1:

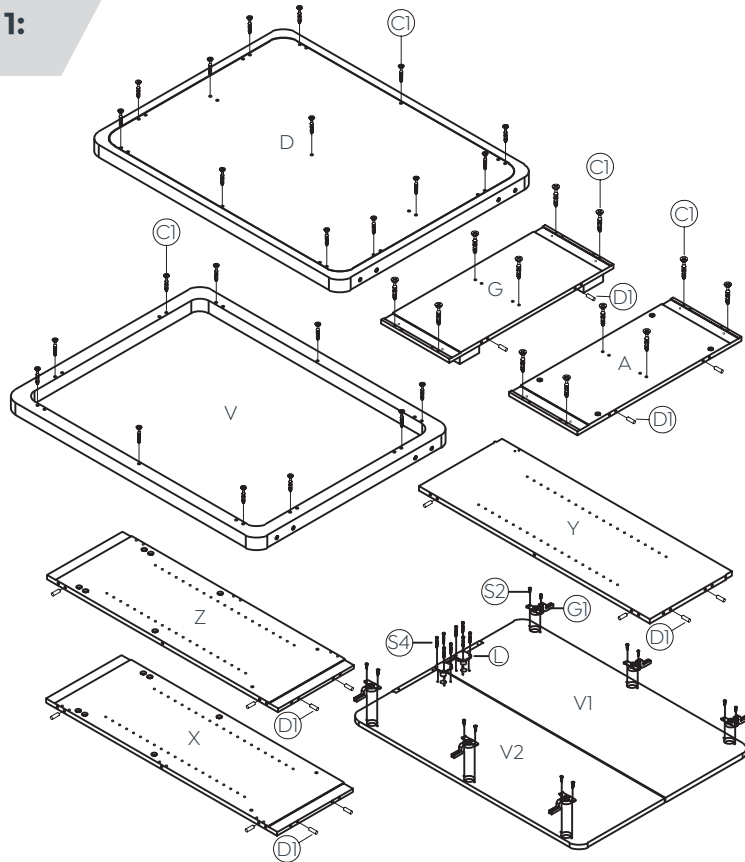

#### Preparation for Top panel A, Bottom panel G, Left side panel X, Right side panel Z, Back panel D, Immovable panel F

1. Insert cam bolts C1 and dowel pins D1 into panels A,G,D,X and Z as illustrated above.
2. Fix hinge stands G1 to panels X,Z with screws S1 as illustrated above.
3. Locate the trim ring on lock and set aside. Insert cylinder of lock L through hole in V2 and secure with S4 screws. Add trim ring to lock on outside of V2.

### STEP 2:

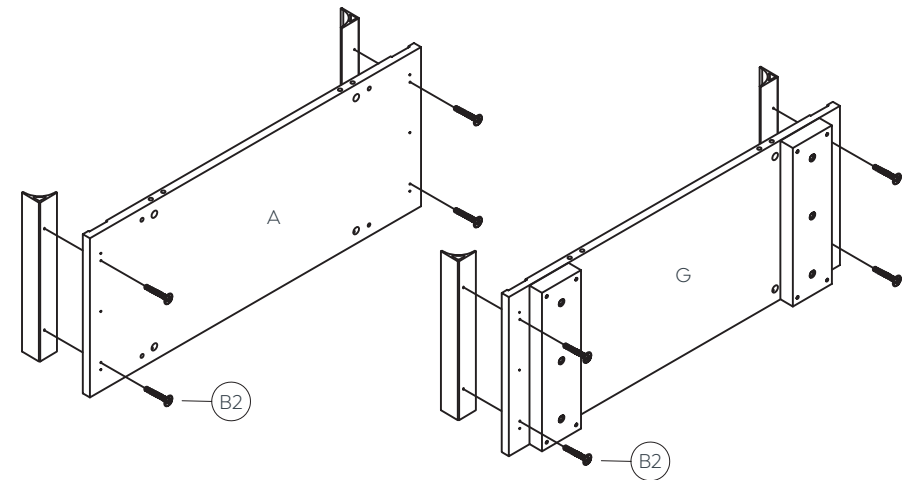

1. Install the aluminum piece and A, G panel together with bolts B2 as illustrated above.

# Rover Range (50-ROMC-0913)

## Assembly Instructions

### STEP 3:

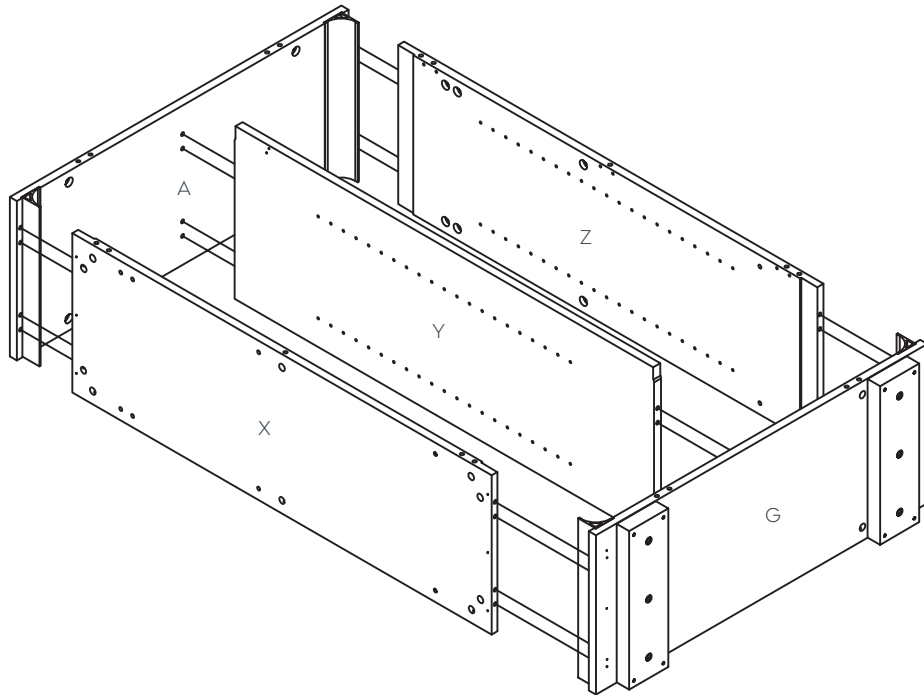

#### Panel X, Z, A and G assembly

1. Insert cam bolts C1 and dowel pins D1 into panels A, G into cams on panel X, Y, Z and tighten in a clockwise direction as illustrated above.

### STEP 4:

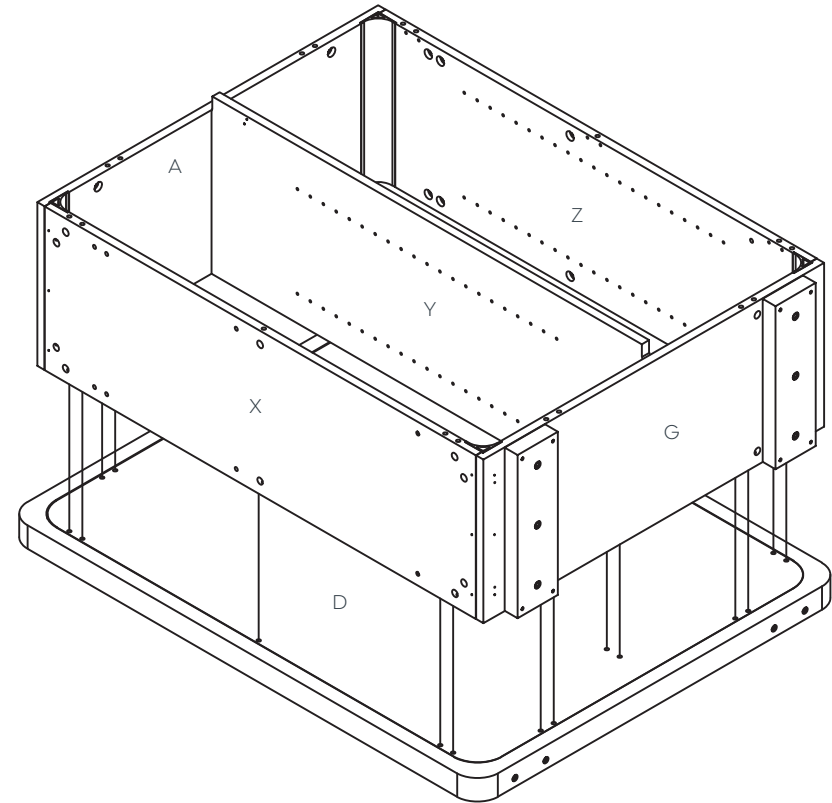

#### Panel D assembly

1. Insert cam bolts C1 and dowel pins D1 on panel D into cams on panel X, Z, A, G, Y and tighten in a clockwise direction as illustrated above.

### STEP 5:

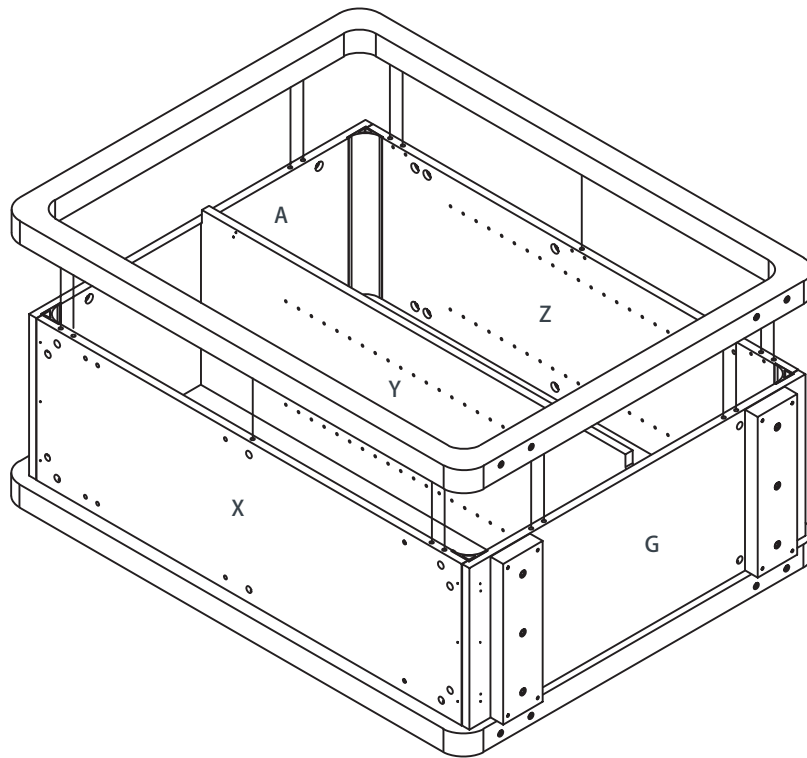

#### Panel G assembly

1. Insert cam bolts C1 and dowel pins D1 on panel G into cams on panel X, Z, A, G, Y and tighten in a clockwise direction as illustrated above.

### STEP 6:

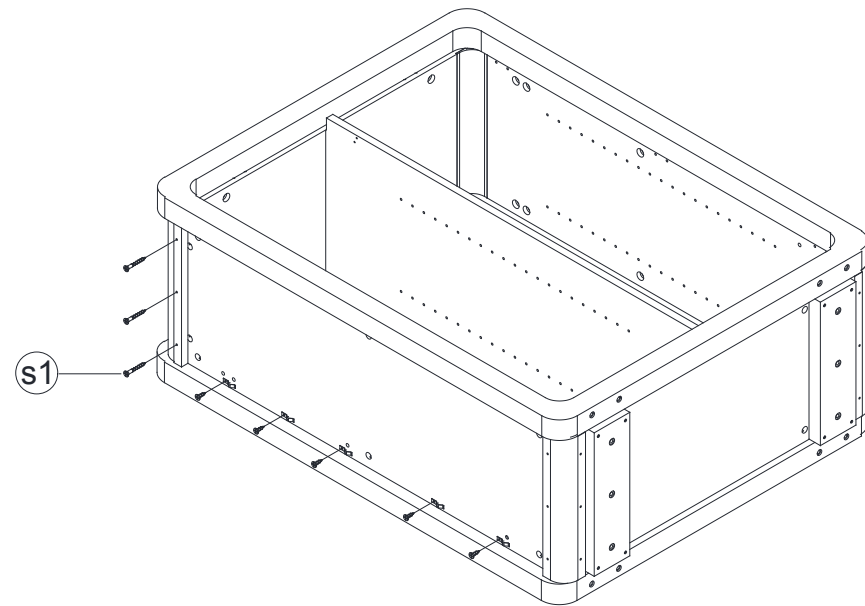

1. Install the aluminum piece and X, Z, A, G panel together with screw S1 as illustrated above.
2. Install the aluminum piece and X, Z, A, G panel together with screw as illustrated above.

# Rover Range (50-ROMC-0913)

## Assembly Instructions

### STEP 7:

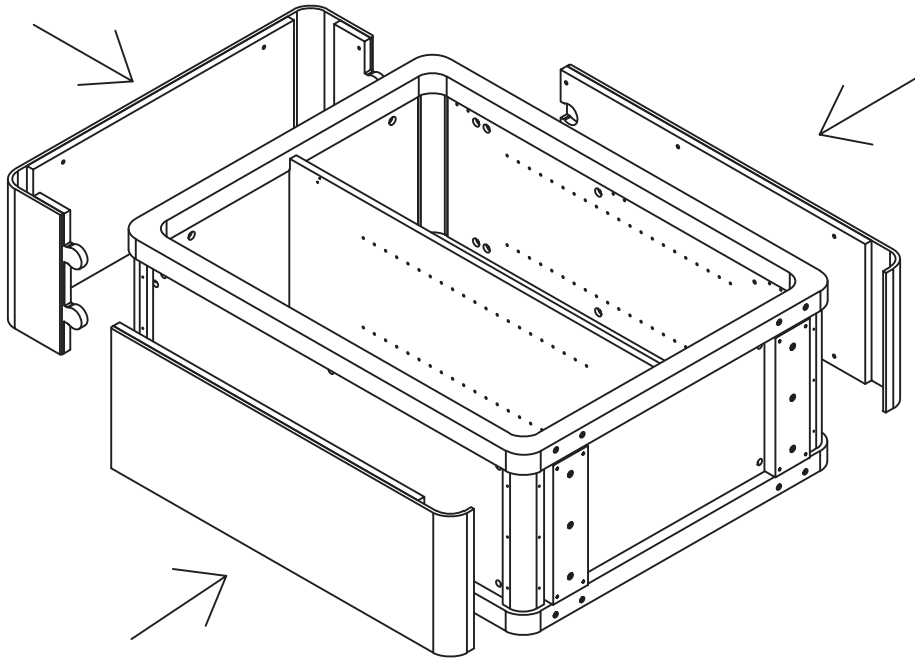

### STEP 8:

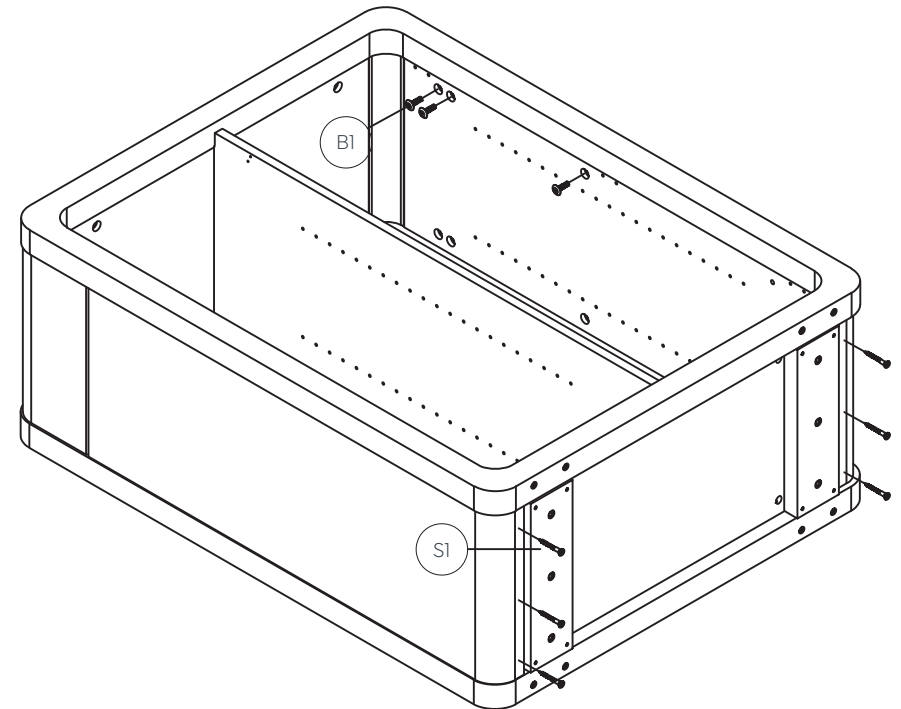

1. Insert fix bolt BI on panel A, X, Z into cam on eva and tighten in clockwise direction as illustrated above.
2. Install the aluminum piece and G panel together with Screw S1 as illustrated above.

## STEP 9:

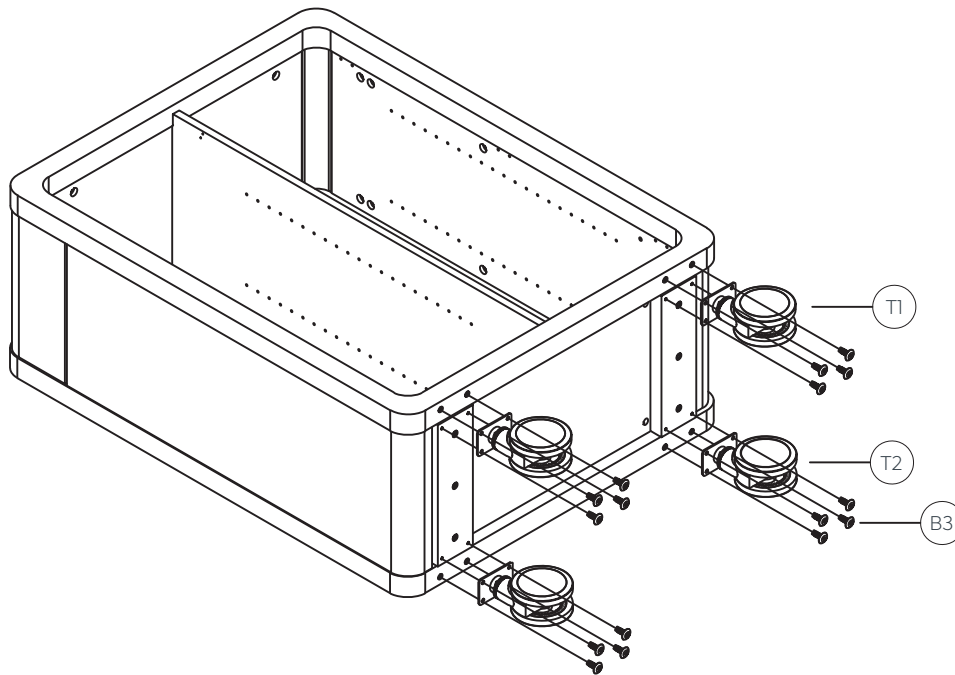

1. Install castors T1 and T2 using screws B3.

## STEP 10:

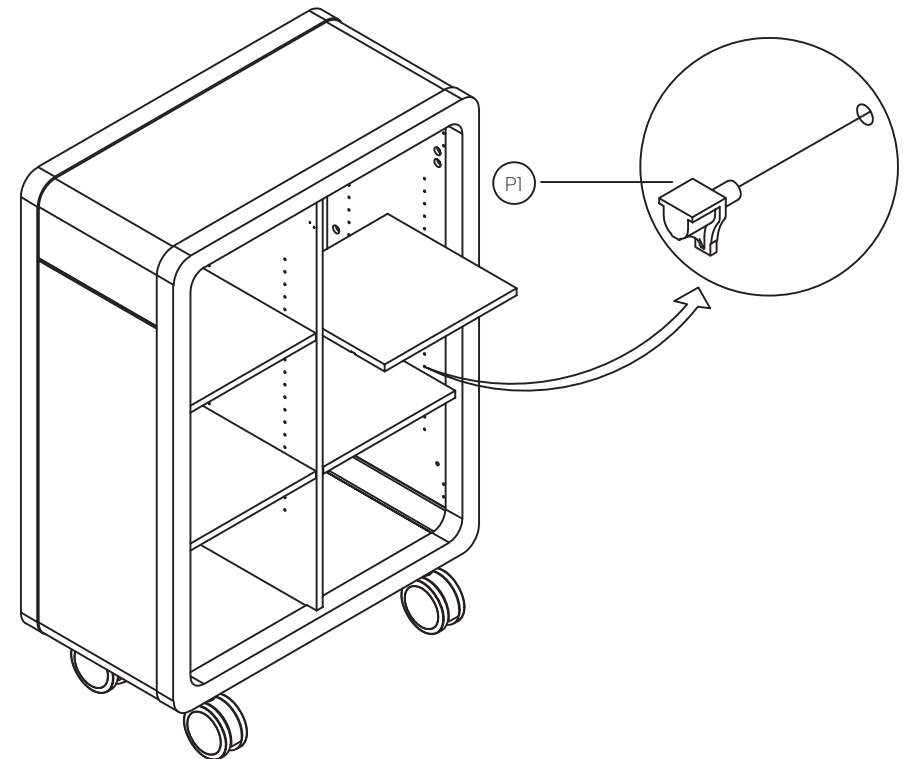

### Moveable shelf E assembly

1. Insert threaded dowel pins P1 into panels X, D and Z as illustrated above.
2. Put the Four panels E on the top of threaded dowel pins P1 as illustrated above.

# Rover Range (50-ROMC-0913)

## Assembly Instructions

### STEP 11:

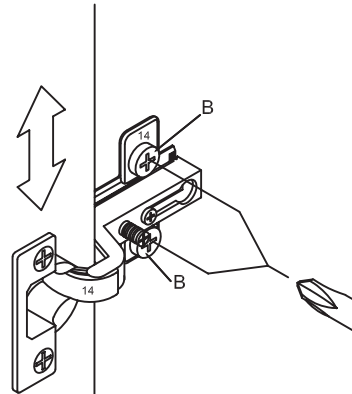
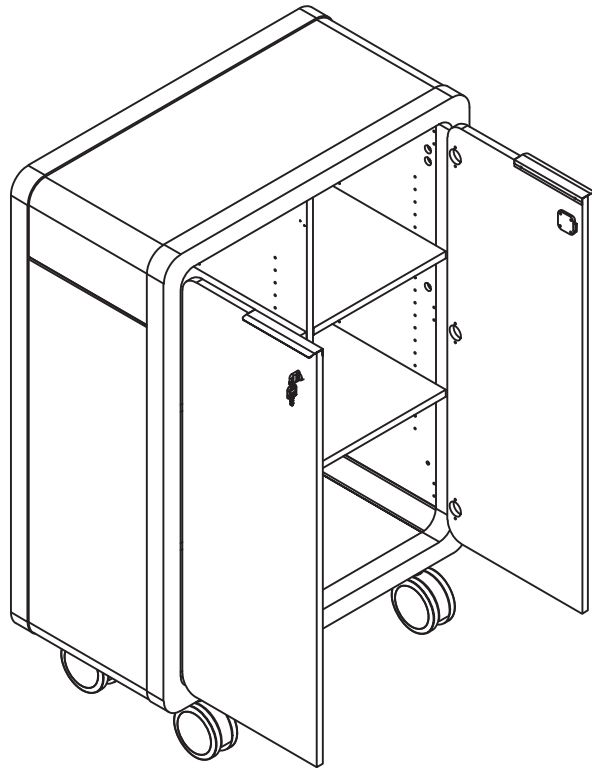

1. Loosen B screws
2. Adjust door vertical
3. Tighten B screws again

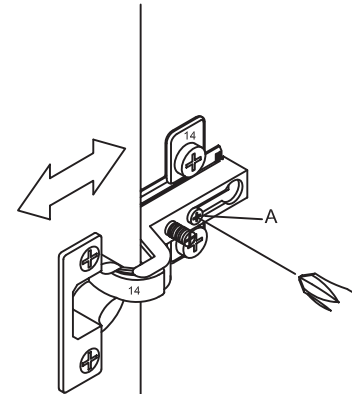

1. Loosen screw A
2. Adjust door in depth
3. Tighten screw A again

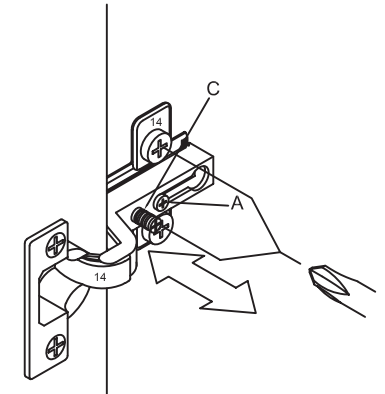

1. Loosen screw A
2. Adjust door sideways with screw C
3. Tighten screw A again



**Complete:**

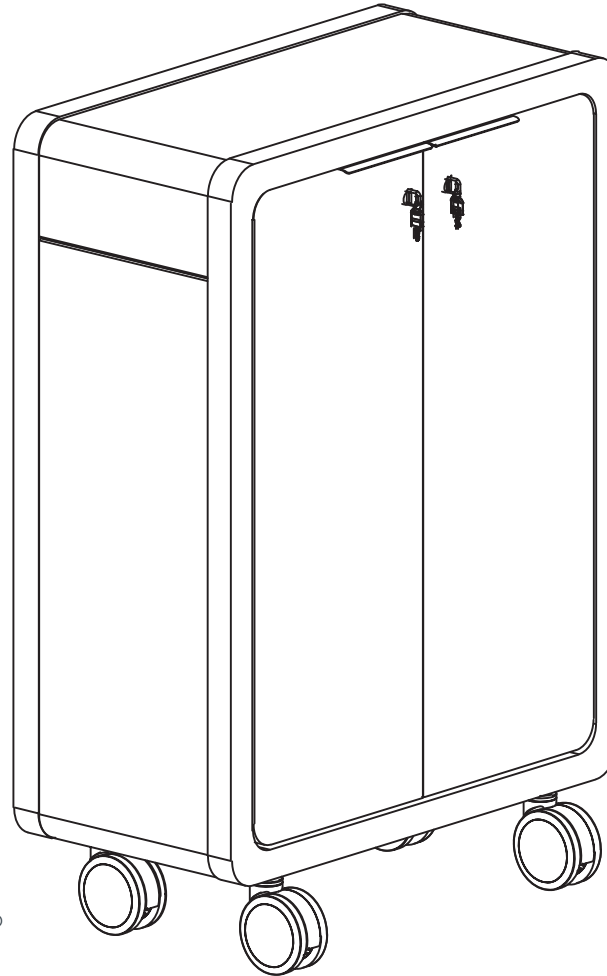

Remove all QC and panel labels and wipe clean using a damp cloth and general household cleaner.