

---

## **Rover Range (50-ROMLK-0916)**

Assembly Instructions

# Rover Range (50-ROMLK-0916)

## Components List

ITEM	DESCRIPTION	QTY
A	Top Panel	1
X	Left Side Panel	1
Z	Right Side Panel	1
D	Back Panel	1
E	Moveable Shelf	4
F	Immovable Panel	1
G	Bottom	1

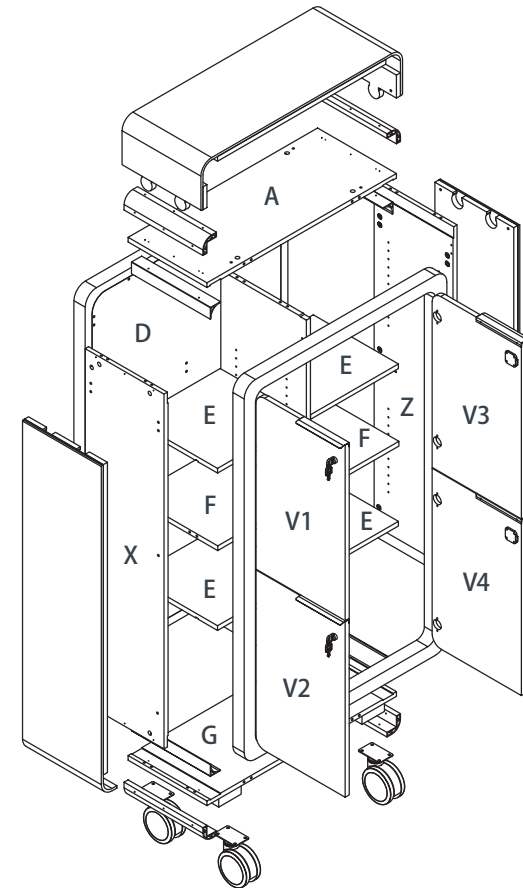
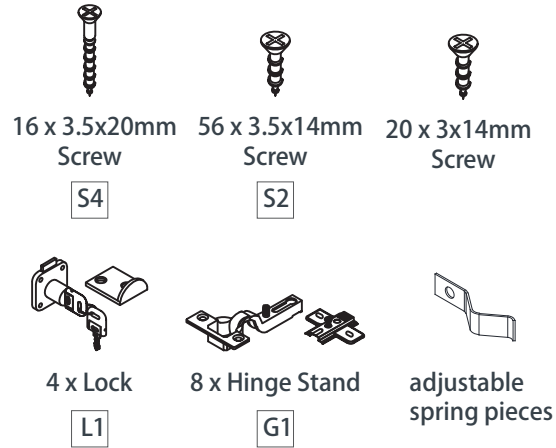

### STEP 1:

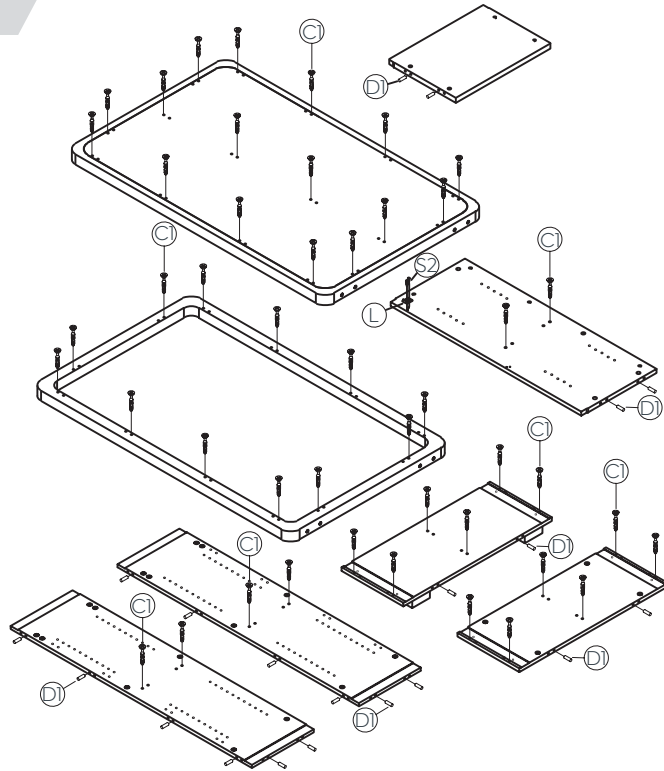

#### Preparation for panel A, G, X, Z, Y, F, D.

1. Insert cam bolts C1 and dowel pins D1 into panels A,G,F,D,X and Z as illustrated above.
2. Locate the trim ring on lock and set aside. Insert cylinder of lock L through hole in Y and secure with S2 screws. Add trim ring to lock on outside of Y.
3. Insert cams bolts C2 and dowel pins D1 into panels Y as illustrated above.

### STEP 2:

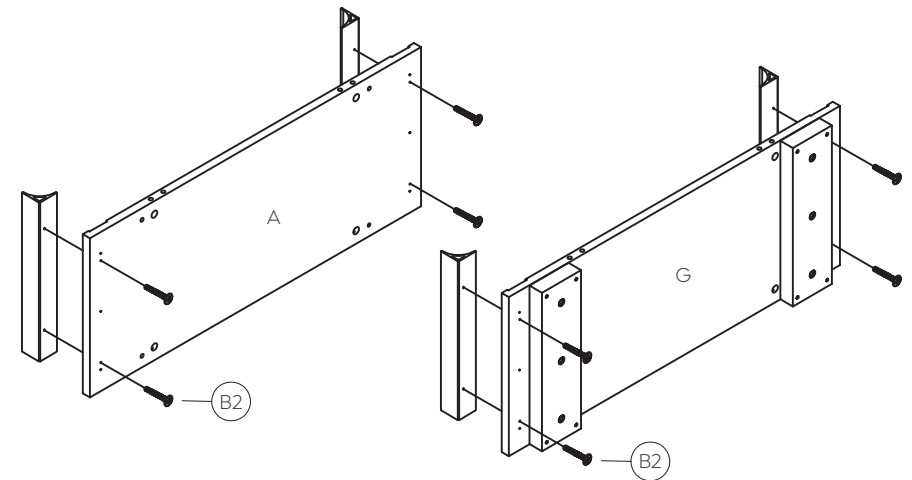

1. Install the aluminum piece and A, G panel together with bolts B2 as illustrated above.

# Rover Range (50-ROMLK-0916)

## Assembly Instructions

### STEP 3:

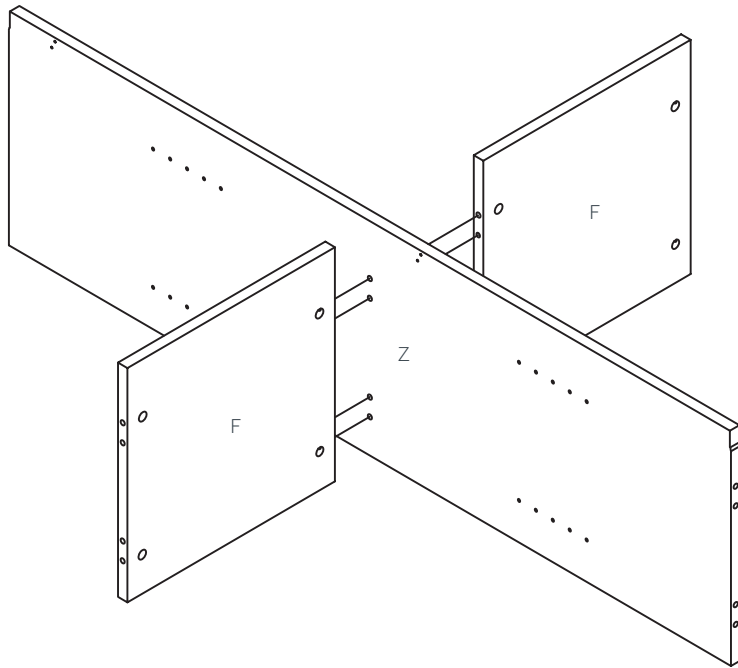

#### Panel Y/F assembly

1. Insert cam bolts C1 and dowel pins D1 into panels Y into cams on panel F and tighten in a clockwise direction as illustrated above.

### STEP 4:

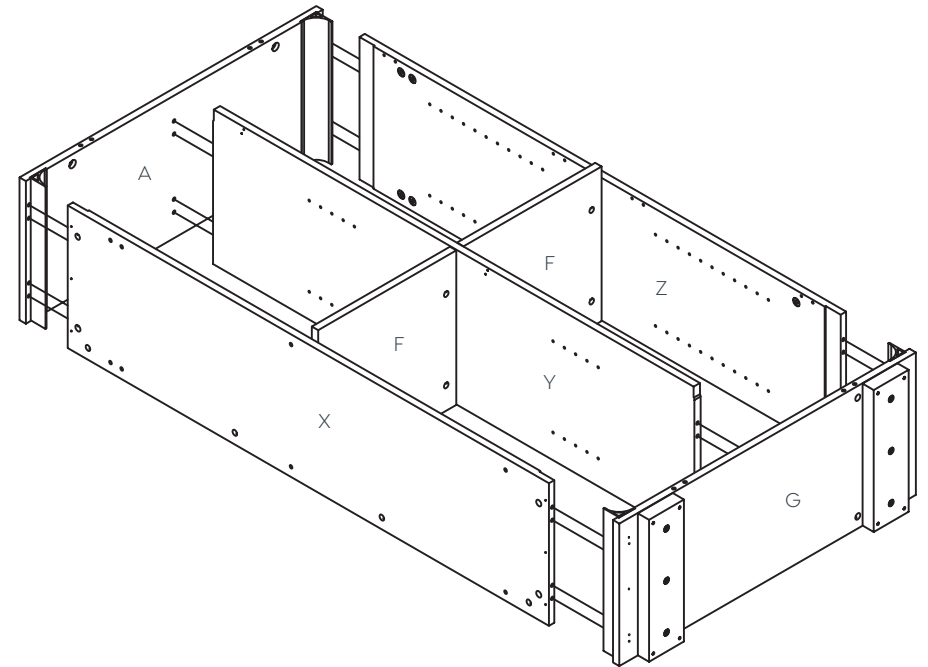

#### Panel A/G assembly

1. Insert cam bolts C1 and dowel pins D1 into panels A, G into cams on panel X, Y, Z and tighten in a clockwise direction as illustrated above.

### STEP 5:

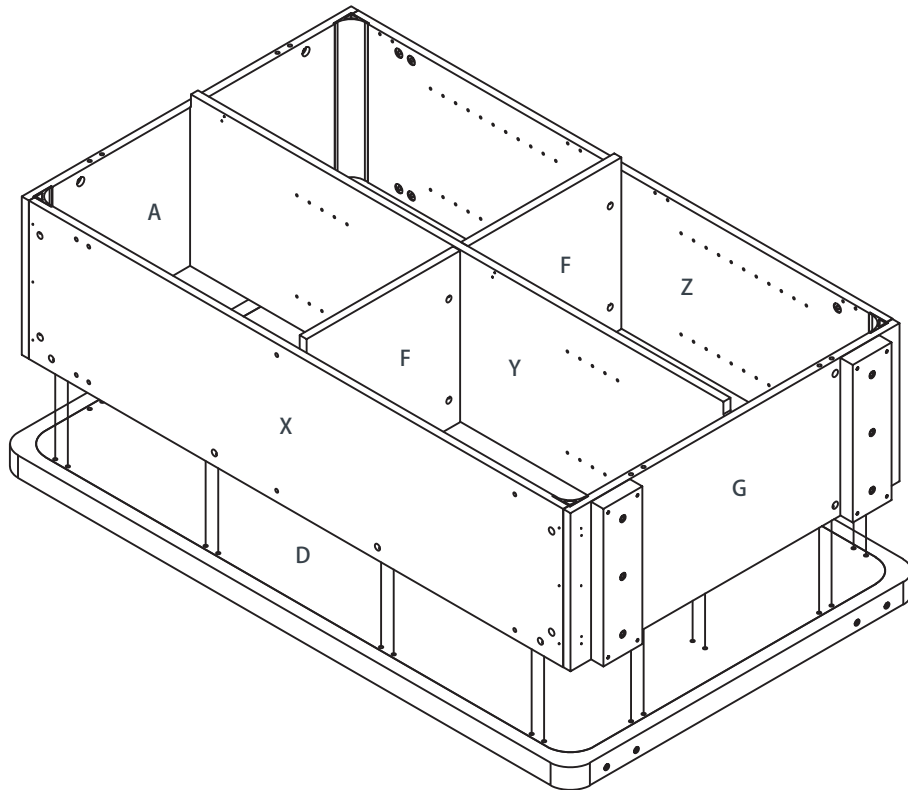

#### Panel D assembly

1. Insert cam bolts C1 and dowel pins D1 on panel D into cams on panel X, Z, A, G, F, Y and tighten in clockwise direction as illustrated above.

### STEP 6:

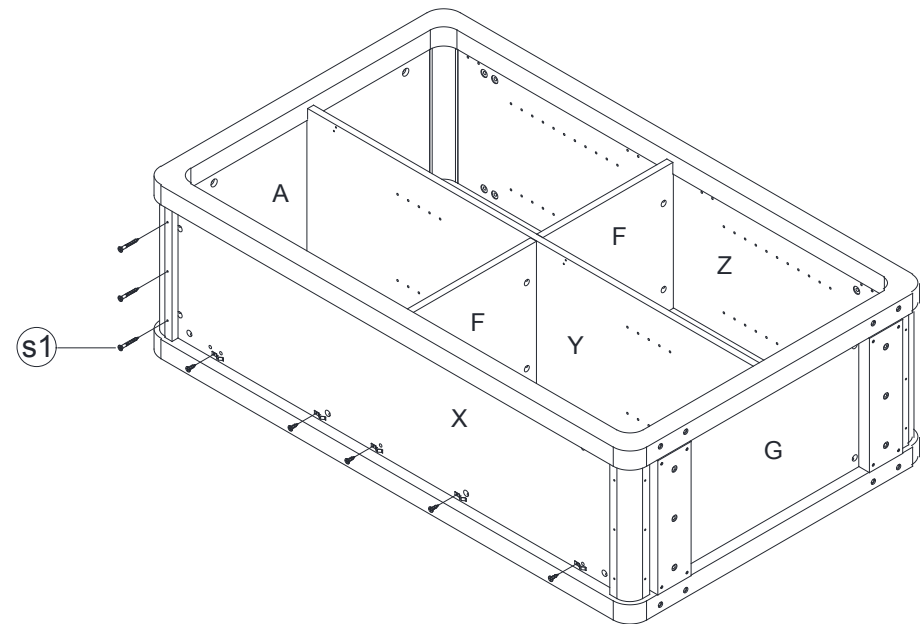

1. Install the aluminum piece and X, Z, A, G panel together with screw S1 as illustrated above.
2. Install the aluminum piece and X, Z panel together with screw as illustrated above.

# Rover Range (50-ROMLK-0916)

## Assembly Instructions

### STEP 7:

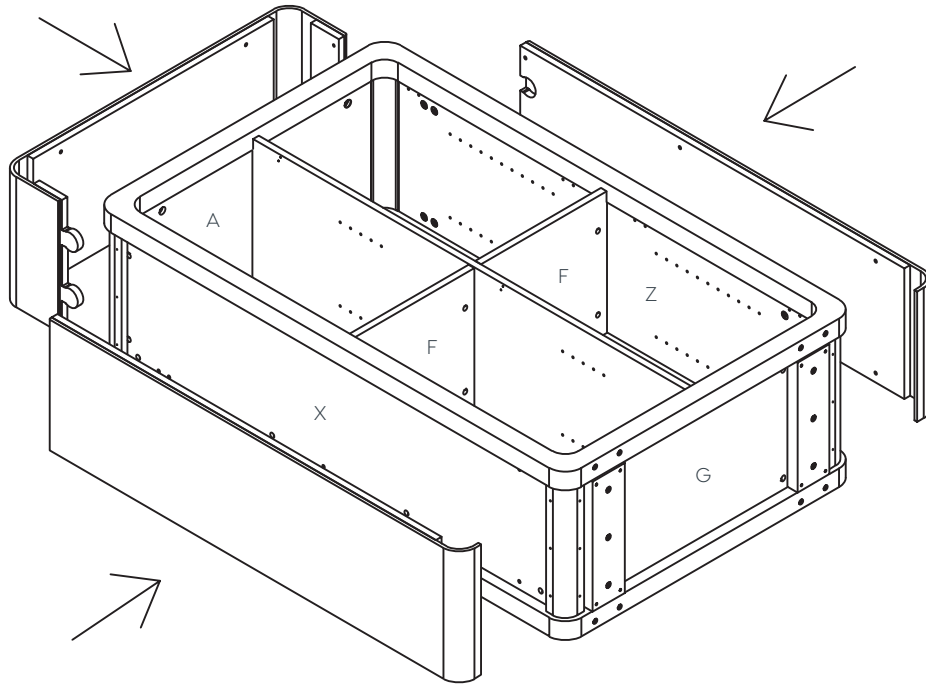

1. Install the aluminum piece and X, Z, A, G panel together with screw S1 as illustrated above.

### STEP 8:

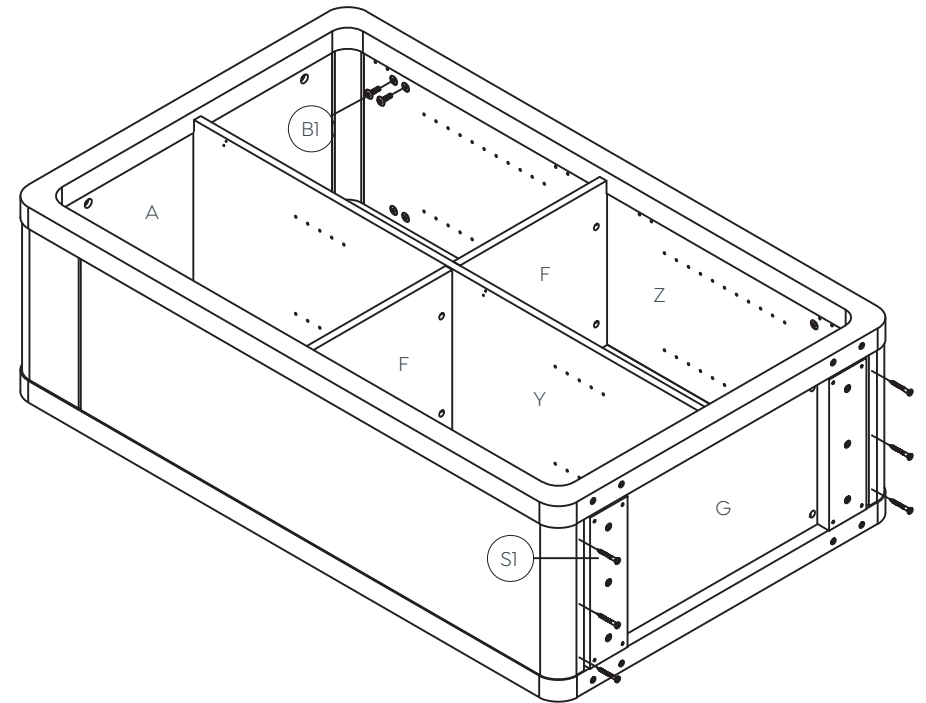

1. Insert fix bolt B1 on panel A, X, Z into cam on eva and tighten in a clockwise direction as illustrated above.  
2. Install the aluminum piece and G panel together with screw S1 as illustrated above.

## STEP 9:

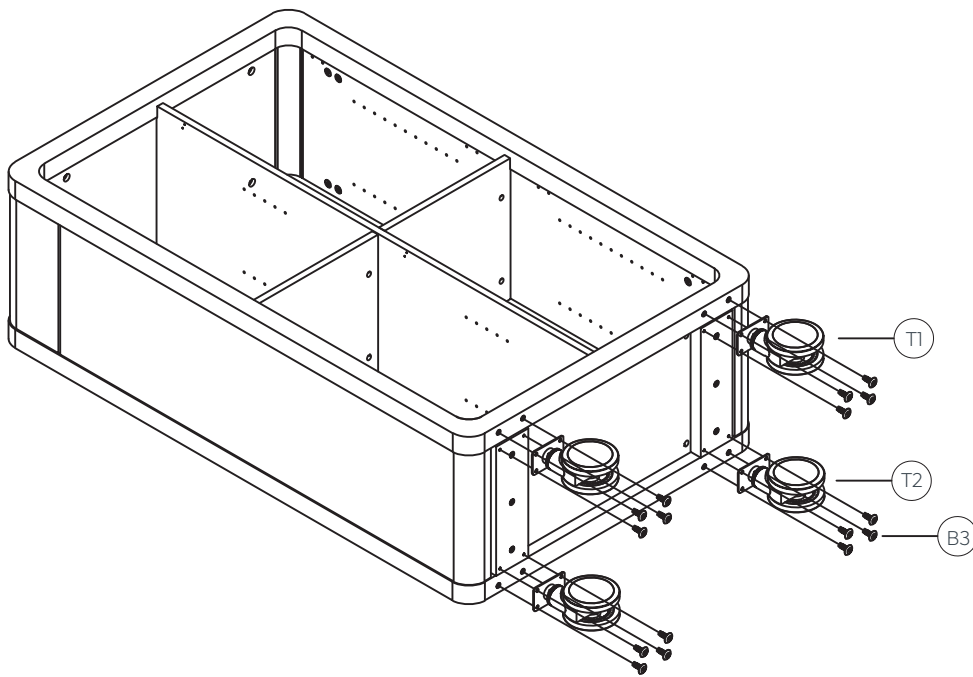

1. Install castors T1 and T2 using screws B3.

## STEP 10:

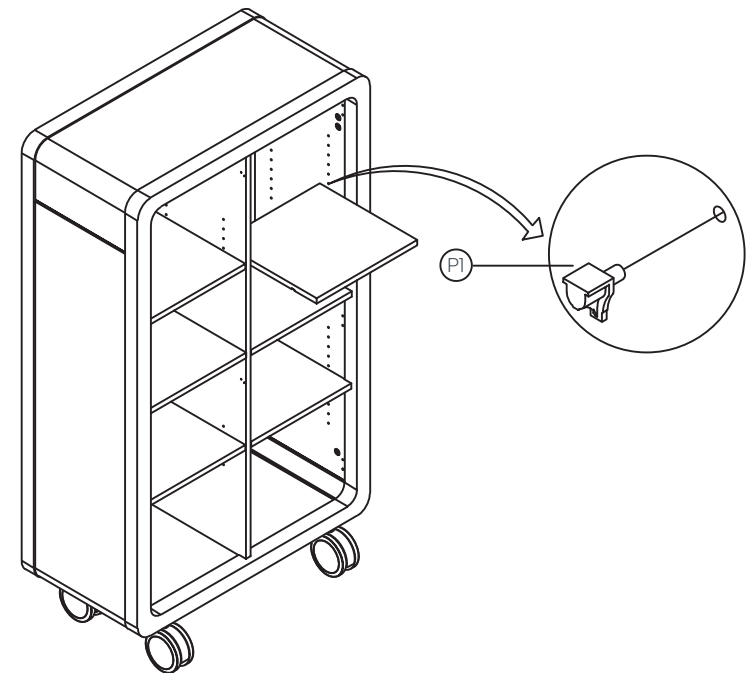

### Moveable shelf E assembly.

1. Insert threaded dowel pins P1 into panels X, D and Z as illustrated above.
2. Put the two panels E on the top of threaded dowel pins P1 as illustrated above.

# Rover Range (50-ROMLK-0916)

## Assembly Instructions

### STEP 11:

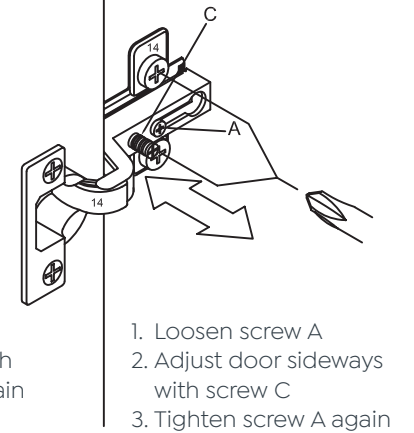
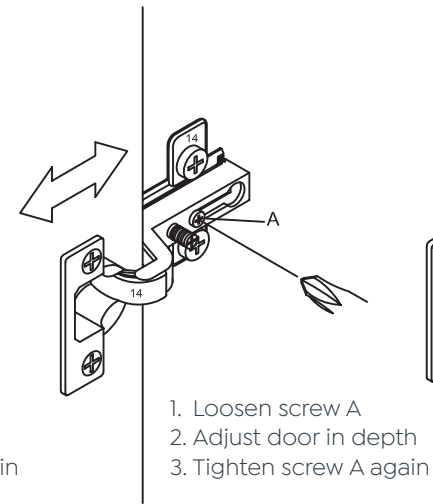
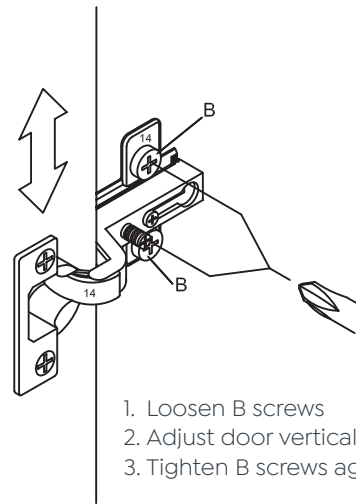
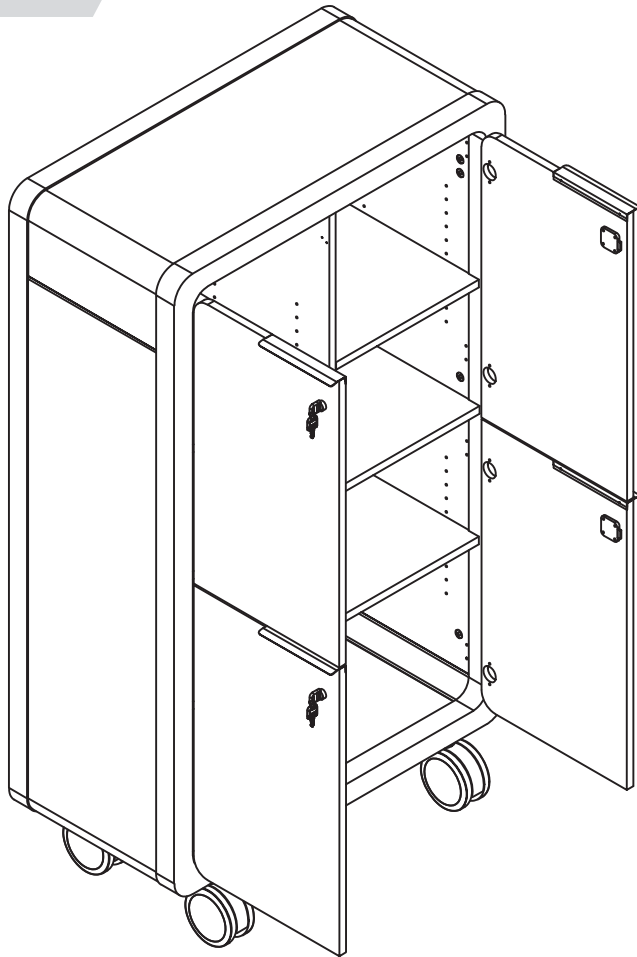



**Complete:**

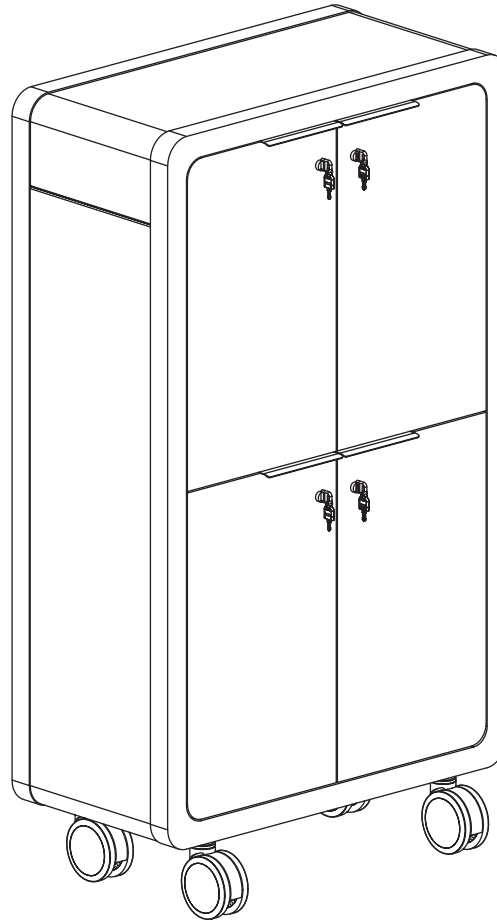

Remove all QC and panel labels and wipe clean using a damp cloth and general household cleaner.