

---

## **Rover Range (50-ROMPL-0916)**

Assembly Instructions

# Rover Range (50-ROMPL-0916)

## Components List



38 x 6x35mm  
Cam Bolt

C1



8 x 8x30mm  
Dowel Pin

D1



38 x 5/8"  
Cam Cover

C2



12 x Threaded  
Dowel Pin

P1



20 x 6x25mm  
Fix Bolt

B1

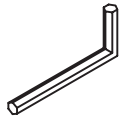

1 x Wrench

A



2 x Castor

T1



2 x Castor

T2

### Pre-installed Parts:

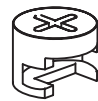

Cam

C5

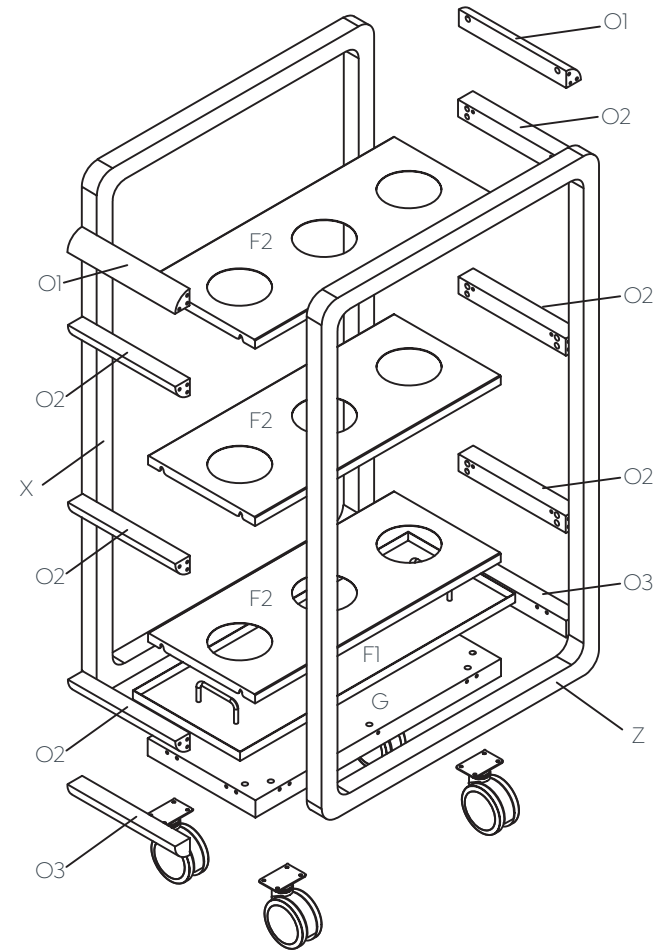

### STEP 1:

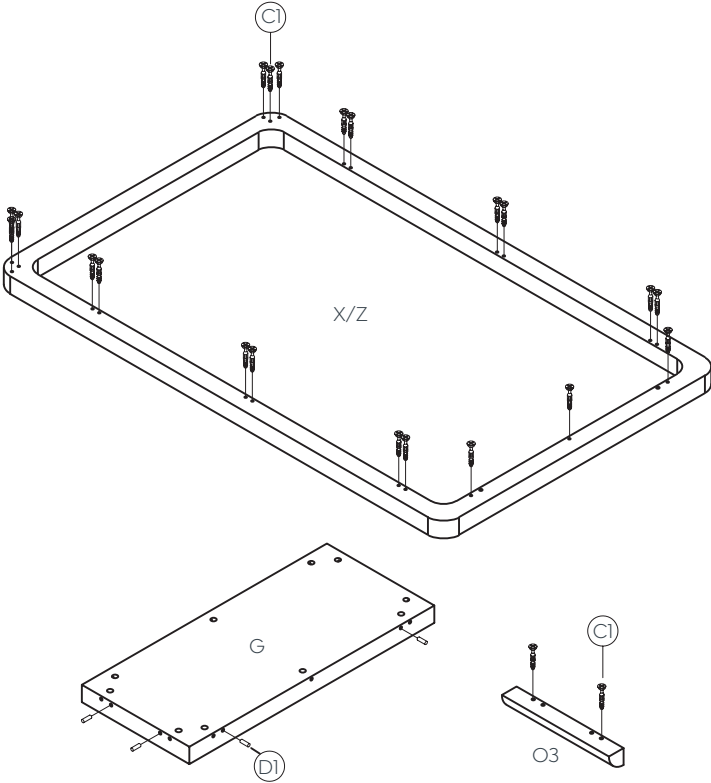

#### Preparation for panel X, Z, O3.

1. Insert cam bolts C1 and dowel pins D1 into panels X, G and Z as illustrated above.

### STEP 2:

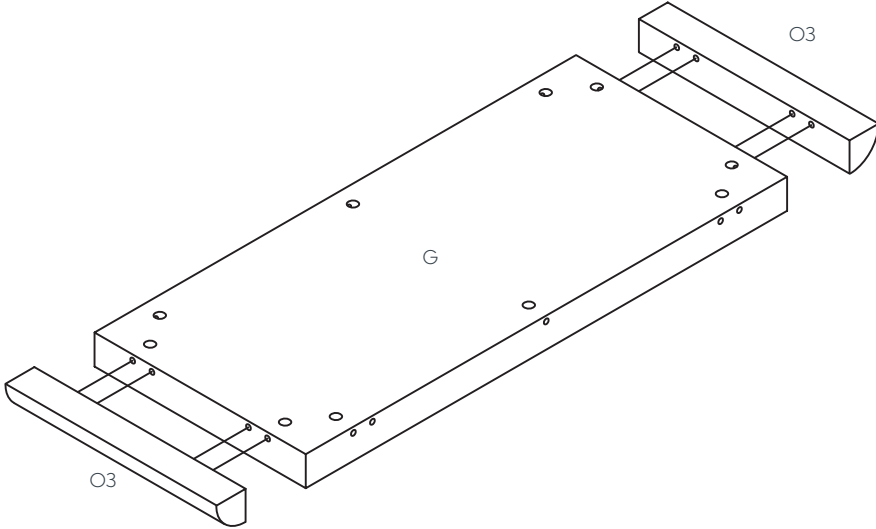

#### Panel O3, G assembly.

1. Insert cam bolts C1 and dowel pins D1 into panel O3 into cams on panel G and tighten in a clockwise direction as illustrated above.

# Rover Range (50-ROMPL-0916)

## Assembly Instructions

### STEP 3:

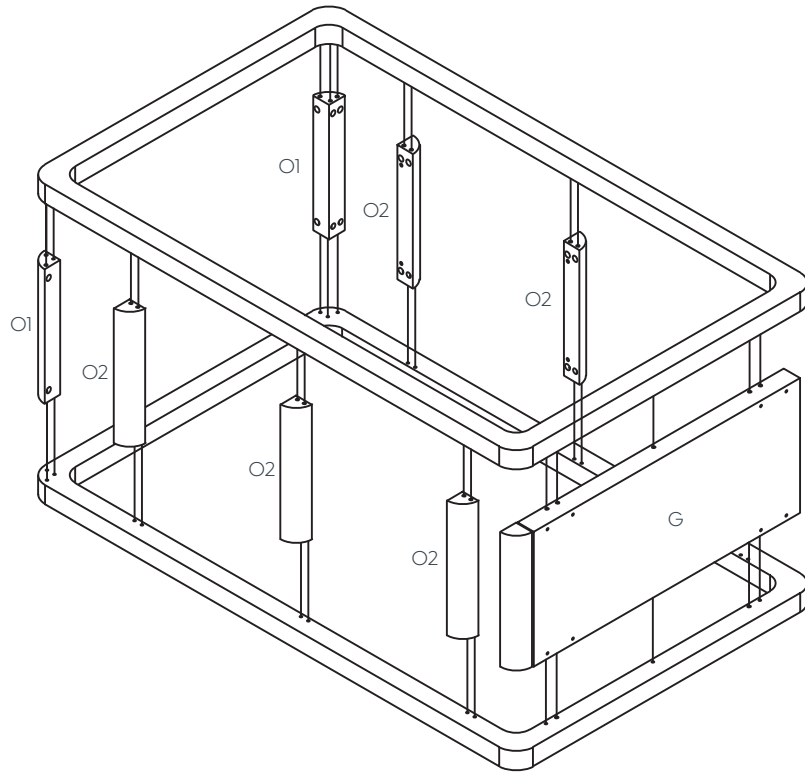

#### Panel Y/Z/O1/O2/O3/G assembly.

1. Insert cam bolts C1 and dowel pins D1 into panels X/Z into cams on panel O1/O2/O3/G and tighten in a clockwise direction as illustrated above.

### STEP 4:

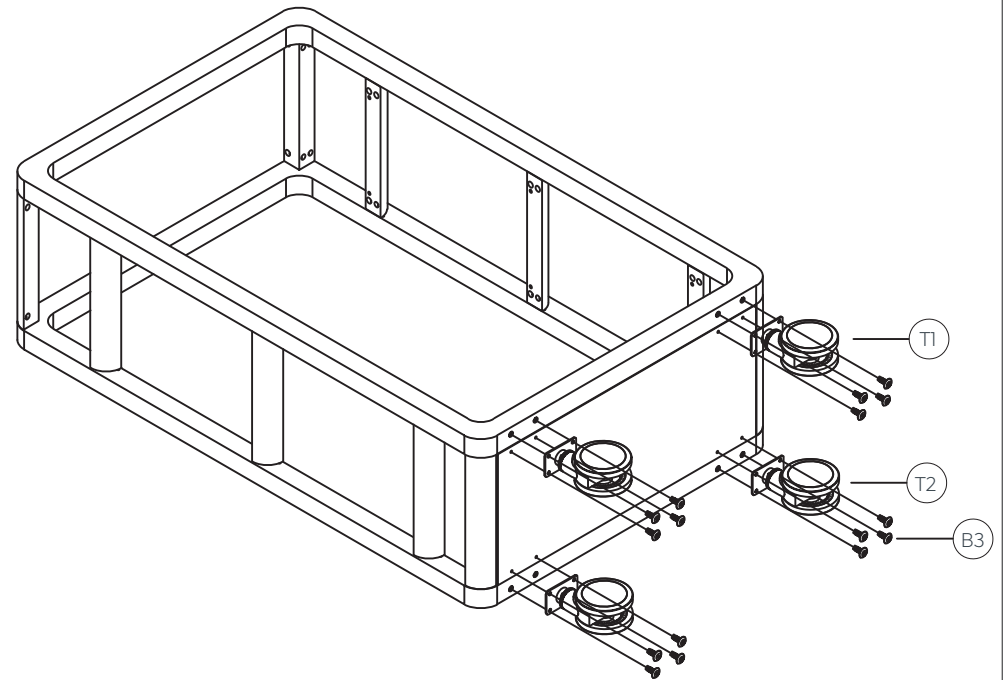

1. Install castors T1 and T2 using screws B3.

## STEP 5:

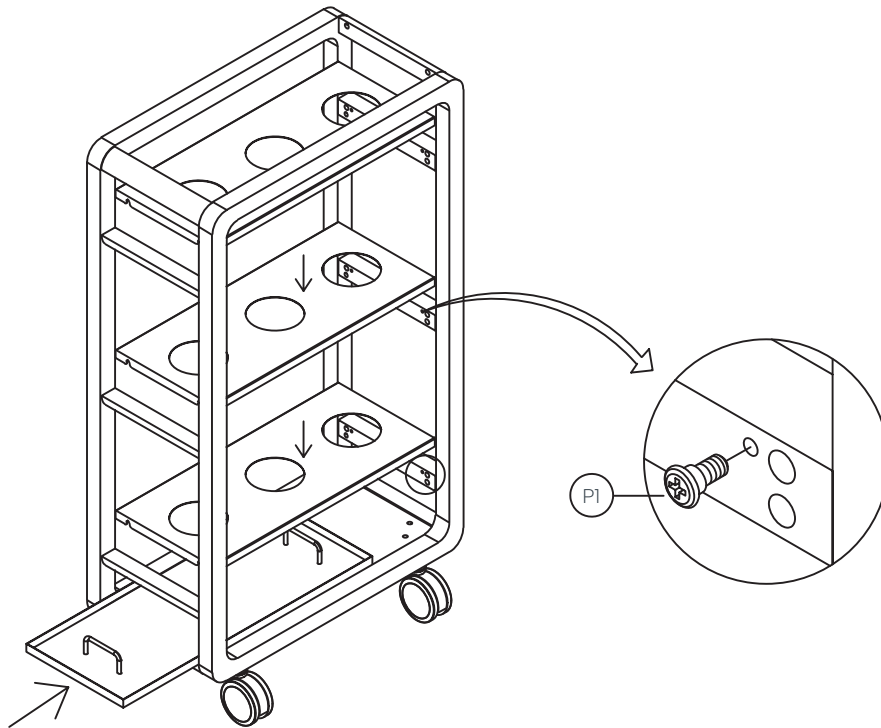

### Moveable shelf E assembly.

1. Insert threaded dowel pins P1 into panels X and Z as illustrated above.
2. Put the three panels F1 on the top of threaded dowel pins P1 as illustrated above.

## Complete:

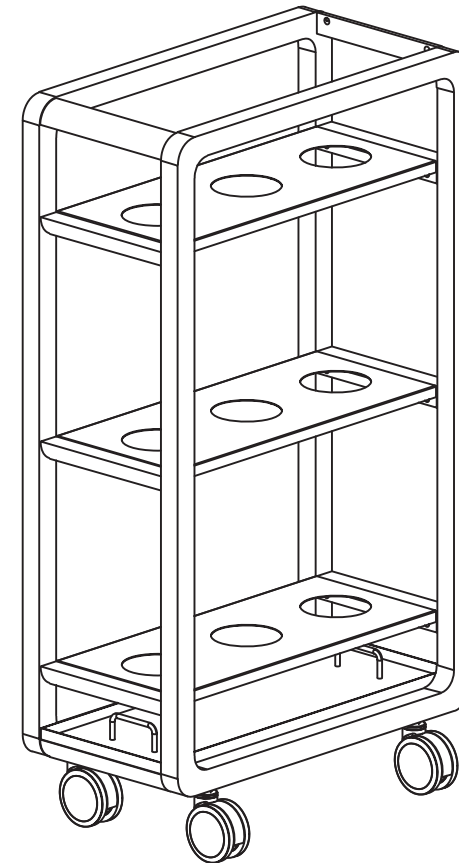

Remove all QC and panel labels and wipe clean using a damp cloth and general household cleaner.